

Silicon Si avalanche photodiode 905nm (Active area 0.5mm T046)

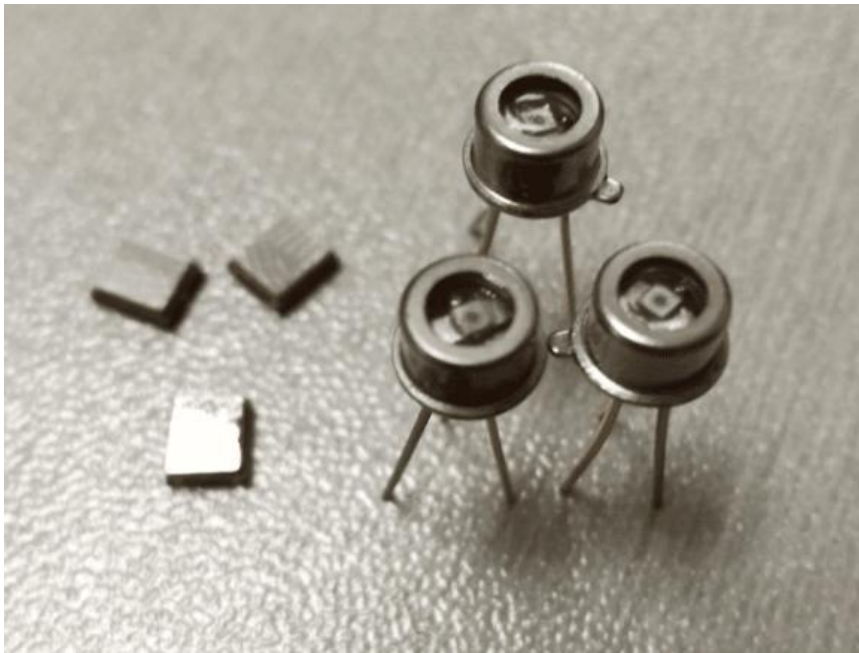

● Product Description

Silicon avalanche photodiode, spectral response range from visible light to near infrared, peak response wavelength 905nm. Large photosensitive surface, high speed response, high gain, low noise.

● Product features

Front-illumination planar chip structure, High-speed response, High gain, Low junction capacitance, Low noise



● Part Number

MP-APD-B-S-905-0.5-T

● Application area

Laser ranging、 Laser radar、 Laser warning

● Core parameters

Spectral Response Range	Active area	Package Method
400-1100nm	0.5mm	T046

● General Parameters

Parameter

Photoelectric performance (@ $T_a=22\pm 3^{\circ}\text{C}$)

PN#	Spectral response range (nm)	Peak response wavelength (nm)	responsivity	Dark current M=100(nA)		Response time (ns)	Operating voltage temperature coefficient (V/°C)	Total capacitance (pF)	Breakdown voltage(V)	
				Typical	Max.				Min.	Max.
MP-APD-B-S-905-0.23-T046	400~1100	905	55	0.2	1	0.6	0.9	1.0	130	220
MP-APD-B-S-905-0.5-T046				0.4	1			1.2		



PN#	Spectral response range (nm)	Peak response wavelength (nm)	Responsivity	Dark current M=100(nA)		Response time (ns)	Operating voltage temperature coefficient (V/°C)	Total capacitance (pF)	Breakdown voltage(V)	
				Typical	Max.				Min.	Max.
MP-APD-B-S-905-0.8-TO46				0.8	2			2.0		
MP-APD-B-S-905-0.23-L				0.2	1			1.0		
MP-APD-B-S-905-0.5-L				0.4	1			1.2		

Structure/Max. absolute rated value

PN#	Packaging method	Active area(mm)	Operating voltage (V)	Operating temperature (°C)	Storage temperature (°C)	Soldering temperature (°C)	Forward current (mA)	Power dissipation (mW)
MP-APD-B-S-905-0.23-TO46	TO-46	0.23	0.9× V BR	-40~85	-45~ 100	260	0.25	100
MP-APD-B-S-905-	TO-4	0.50						



0.5-TO46	6						
MP-APD-B-S-905- 0.8-TO46	TO-4 6	0.80					
MP-APD-B-S-905- 0.23-L	LCC3	0.23					
MP-APD-B-S-905- 0.5-L	LCC3	0.50					

PN

Name	PN#	Description
Silicon Avalanche Photodiode	MP-APD-B-S-905-0.23-TO46	Spectral response range: 400-1100nm Peak response wavelength: 905nm Photosensitive surface diameter: 0.23mm Package: TO46
Silicon Avalanche Photodiode	MP-APD-B-S-905-0.5-TO46	Spectral response range: 400-1100nm Peak response wavelength: 905nm Photosensitive surface diameter: 0.50mm Package: TO46
Silicon Avalanche Photodiode	MP-APD-B-S-905-0.8-TO46	Spectral response range: 400-1100nm Peak response wavelength: 905nm Photosensitive surface diameter: 0.80mm Package: TO46
Silicon Avalanche Photodiode	MP-APD-B-S-905-0.23-L	Spectral response range: 400-1100nm Peak response wavelength: 905nm Photosensitive surface diameter: 0.23mm Package: LCC3



Name	PN#	Description
Silicon Avalanche Photodiode	MP-APD-B-S-905-0.5-L	<p>Spectral response range: 400-1100nm</p> <p>Peak response wavelength: 905nm</p> <p>Photosensitive surface diameter: 0.50mm</p> <p>Package: LCC3</p>

Typical characteristic curve

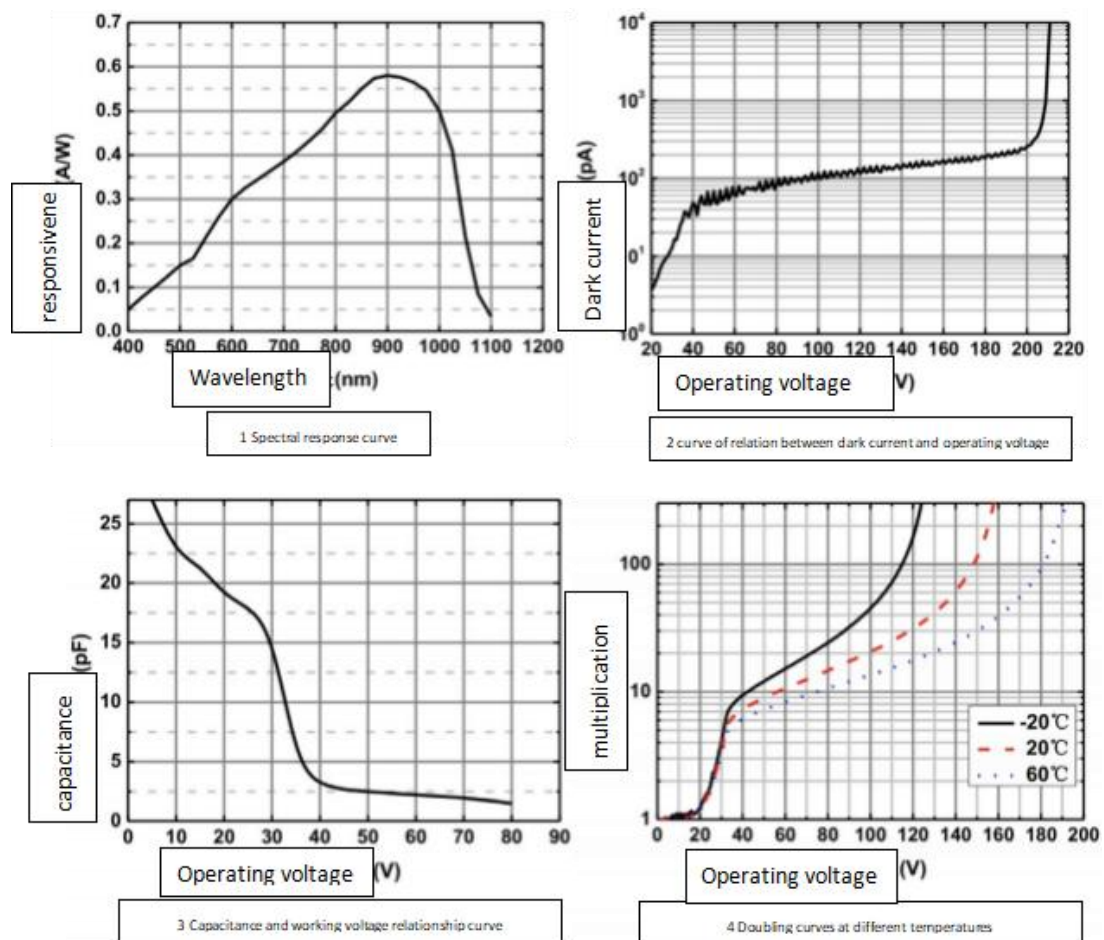

Package shape, size and pin definition:

APD-SI-905-2/5/8-TO46 (three-pin and two-pin packages)

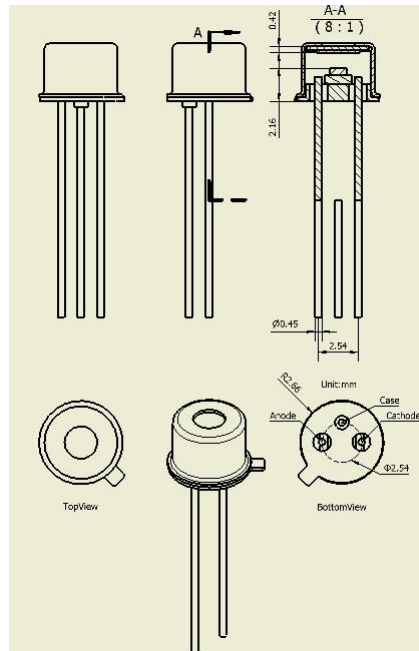

APD-SI-905-2/5-LCC3

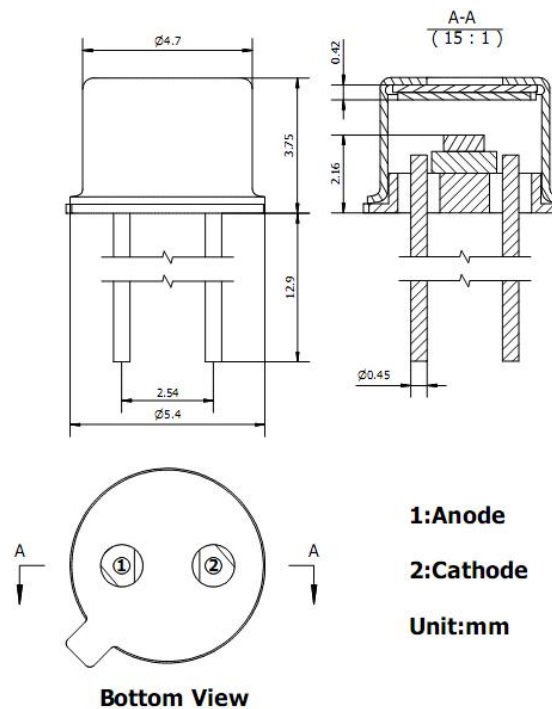

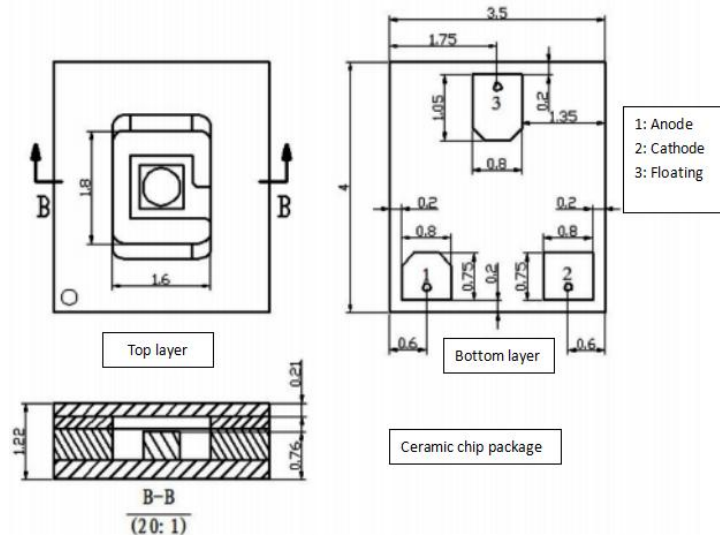

Equivalent circuit and application circuit

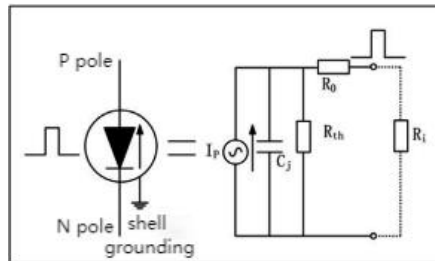

Figure 5 Equivalent circuit

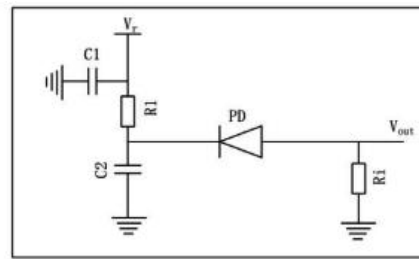

Figure 6 Application circuit

Note:

C1-filter capacitor, filters out the noise of bias voltage VR.

C2-bypass capacitor, provides a ground loop for AC signal.

R1-current limiting resistor, prevents damage to the detector when bias voltage

VR is too high.

Ri-sampling resistor, converts photocurrent into voltage signal.

Order Information

PN#

[APD-SI-response wavelength-active area-packaging form]