

# InGaAs amplified photodetector 800-1700nm (140MHz)



## ● Product Description

Indium Gallium Arsenide (InGaAs) photodetector is a rated bandwidth, with the fixed gain photodetector to detect optical signals. The optical signal is input from the photoelectric sensor sensing surface and output in the form of voltage through BNC. This product can measure optical signals in the wavelength range of 800nm to 1700nm. For specific performance parameter data, please refer to the appendix table. The Idealphotonix photodetector housing has a mounting hole with an imperial 1/4"-20 thread, which can be

easily installed and fixed. The housing also comes with two different sizes of threaded rings, which are suitable for industrial applications and scientific research applications respectively, and can be easily adapted to external optical components such as filters, attenuators, lenses, FC fiber adapters, etc. The product includes a plastic dust cover. For specific installation, please refer to Chapter 3. Each photodetector is equipped with a DC linear power supply with an output of  $\pm 9V$ . The input rated voltage of the DC power supply is 220VAC/50H

## ● Product features

Low noise, less than  $\pm 1mV$ 、 Small overshoot, overshoot voltage less than 2.5%、 Gain stability: gain error is less than 1%、 Dark bias voltage output noise: less than 1mV (rms)

## ● Part Number

MP-PDAM10A7B4G-InGaAs

## ● Application area

Display panel inspection 、 LED lighting stroboscopic analysis 、  
Measurement of flashing frequency and power of toy lights 、 Gas analysis



## ● Core parameters

Wavelength	Bandwidth
800-1700nm	140MHz

## ● Dimension Drawing

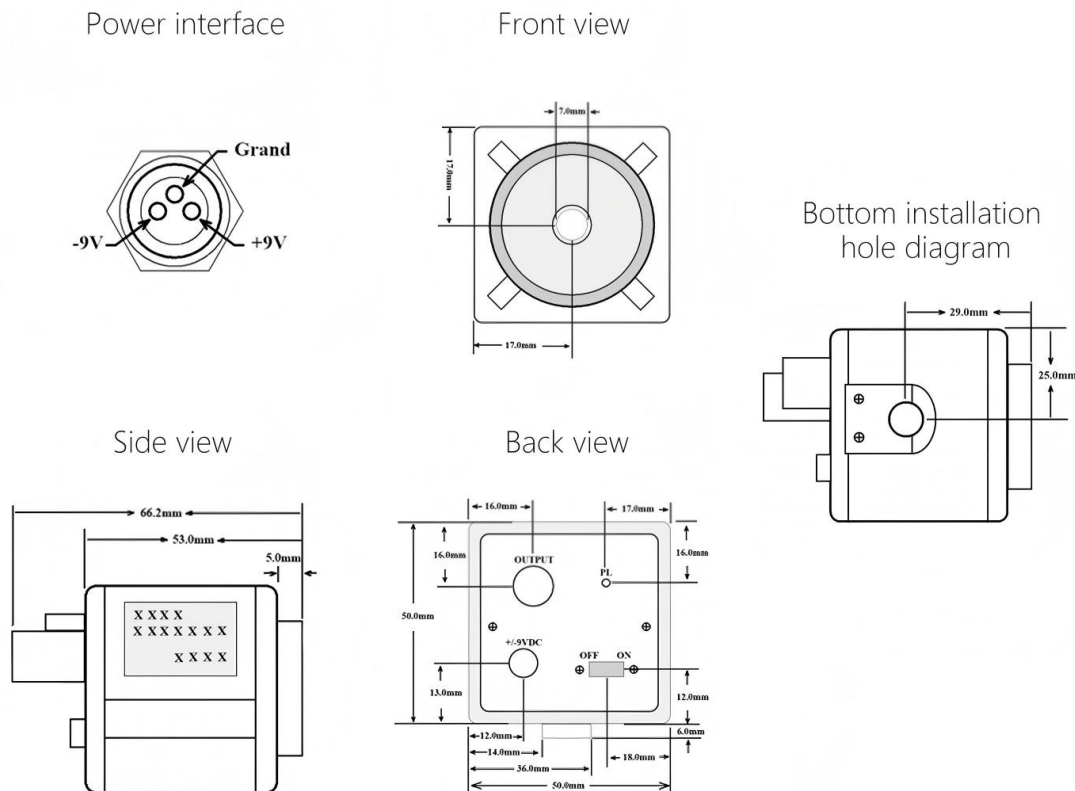

## ● General Parameters

parameter

PN#	MP-PDA M 005B-Si	MP-PDA M 36A5B6G-SI	MP-PDA M 20A6B4G- InGaAs
-----	------------------	------------------------	-----------------------------



Electrical characteristics			
Input voltage	±9VDC, 60mA	±9VDG 100mA	±9VDC. 100mA
Probe	Silicon PIN	Silicon PIN	InGaAs PIN
Photosensitive surface	2.65mm * 2.65mm	3.6mm * 3.6mm	Diameters@2 mm
wavelength	400 nm - 1100 nm	320 nm - 1100 nm	800 nm - 1700 nm (Optional Extended 2600 nm)
Peak response	0.62A/W @850nm	0.6 A/W @960nm	0.9 A/W@1550nm
	43.6mV/ uW @850nm	1 mV/ nW @960nm	9mV/uW@1550nm
Saturation optical power	113pW@ 850nm (Hi-Z)	6uW @960nm (Hi-Z)	660 uW@1550nm (Hi-Z)
Bandwidth	DC • -5MHz	DC - 200kHz	DC - 5MHz
NEP	7.2 pW /4HZ <sup>1/2</sup>	2.2 pW /HZ <sup>1/2</sup>	64.5 pW /HZ <sup>1/2</sup>
Output noise (RMS)	700 uV	1 mV • typ	1.3 mV. typ
Dark current bias (MAX)	±5 mV	±1 mV	±5 mV
Rising edge/falling edge (10%-90%)	65 ns	1.7 us	68ns
Output voltage			
Hi-Z	0-SV (Hi-Z)	0-6V (Hi-Z)	0-6V (Hi-Z)



500	0 • 2.5V (50ohm)	0 • 25V (50ohm)	0 • 25V (50ohm)
Gain multiple			
Hi-Z	67.5 kV/A	1.68 MV/A	10 kV/A
50Q	33.8 kV/A	0.84 MV/A	5kV/A
Gain accuracy ( typ )	±1%	±1%	±1%
Other parameters			
	Toggle switch	Toggle switch	Toggle switch
Output Interface	BNC	BNC	BNC
size	53*50*50mm	53*50*50mm	53*50*50mm
weight	150g	150g	150g
Operating temperature	10-50 degrees	10-50 degrees	10-50 degrees
Storage temperature	-25°C - 70°C	-25°C - 70°C	-25°C - 70°C

## Reference for the amplified, & fixed gain model of InGaAs photodetector

model	wave length	bandwidth	Rise time	Gain		RMS Noise	NEP	Sensing surface	Operating temperature	power supply
				Hi-Z Load	50Ω Load					



MP-PD A10A8B 4G-NIR	800 - 1700 nm	DC - 140 MHz	2.5 nS	1*10 <sup>4</sup> V/A	5*10 <sup>3</sup> V/A	760 μV. typ	4.8*1 0 <sup>-12</sup> W /√ HZ	φ1 mm	10-50°C	Includ ed (± 9V)
MP-PD A05A7B 4G-NIR	800 - 1700 nm	DC - 25M Hz	14 nS	1.2* 10 <sup>4</sup> V /A	6*10 <sup>3</sup> V/A	1 mV. typ	1.9*1 0 <sup>-11</sup> W /√ HZ	φ0.5 mm	10-50°C	Includ ed (± 9V)
MP-PD A10A7B 4G-NIR	800 - 1700 nm	DC - 12M Hz	29 nS	1*10 <sup>4</sup> V/A	5*10 <sup>3</sup> V/A	800 μV. typ	2.6*1 0 <sup>-11</sup> W /√ HZ	φ1 mm	10-50°C	Includ ed (± 9V)
MP-PD A20A6B 4G-NIR	800 - 1700 nm	DC - 5MH z	70 nS	1*10 <sup>4</sup> V/A	5*10 <sup>3</sup> V/A	1.3 mV. typ	6.5*1 0 <sup>-11</sup> W /√ HZ	φ2 mm	10-50°C	Includ ed (± 9V)
MP-PD A30A6B 4G-NIR	800 - 1700 nm	DC - 2MH z	175 nS	1*10 <sup>4</sup> V/A	5*10 <sup>3</sup> V/A	800 μV. typ	6.3*1 0 <sup>-11</sup> W /√ HZ	φ3 mm	10-50°C	Includ ed (± 9V)



Spectral sensitivity

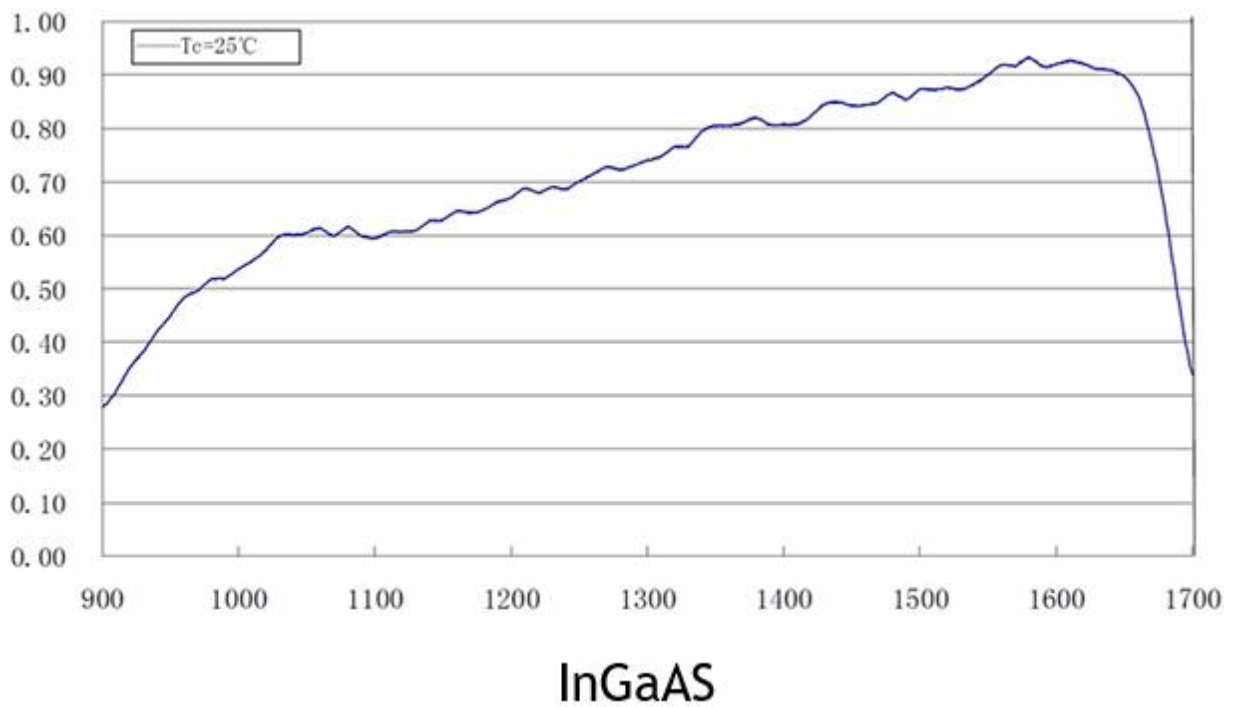
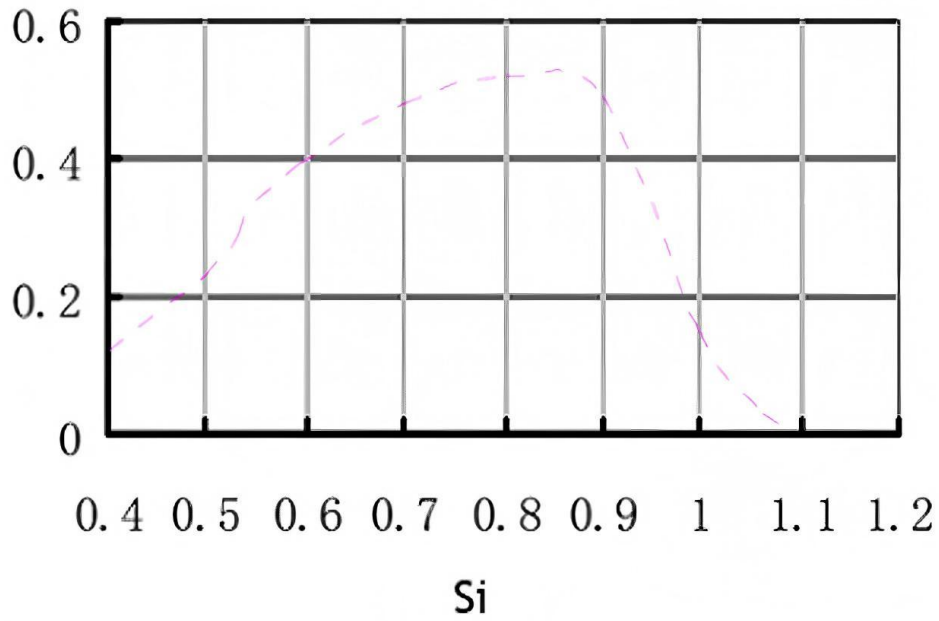

AC transfer characteristics

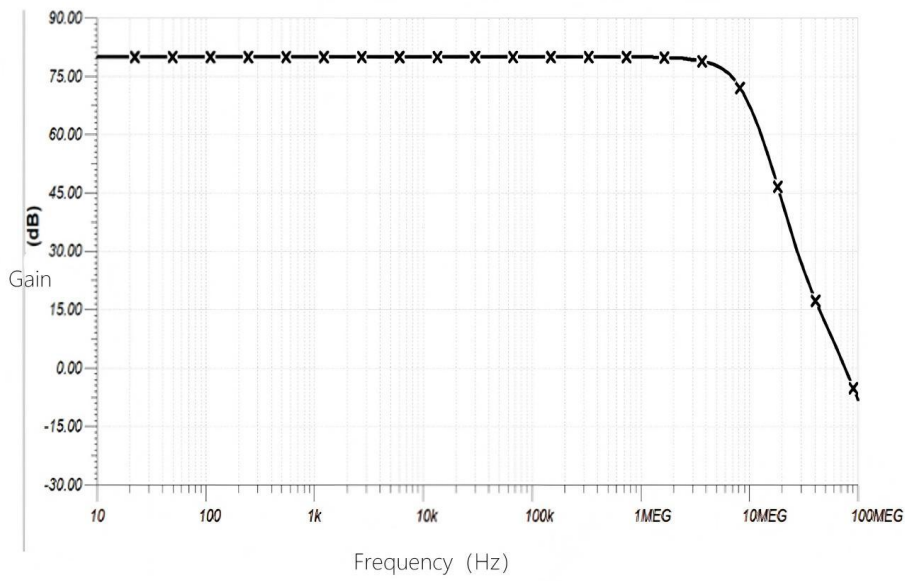

## Appearance and installation

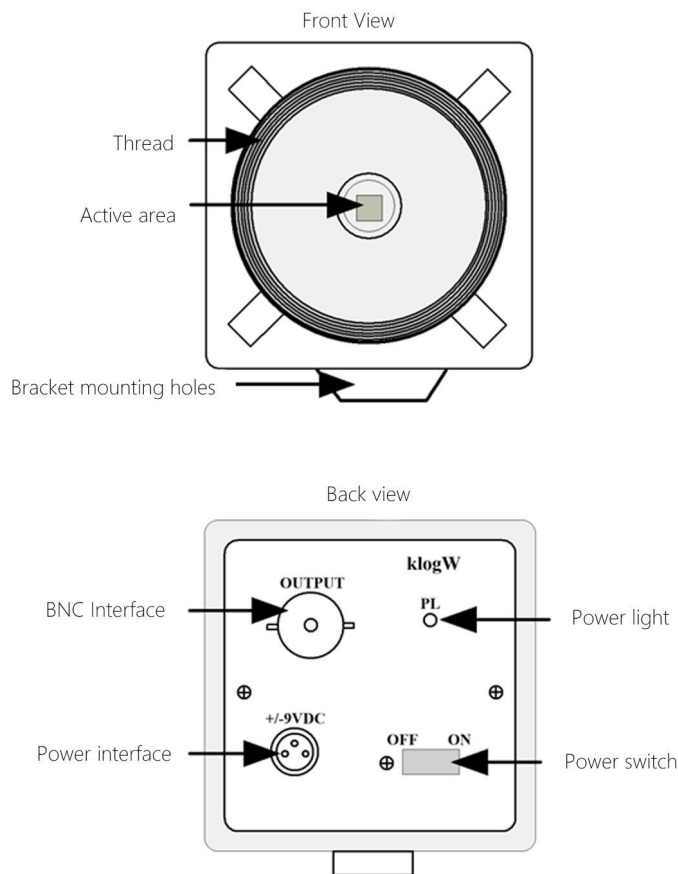

## Test cases :

Test light source:

PN: PL-DFB-9672.4-B-A81-PA

SN:DO3431e-q2-Bo2-A19

Test conditions: 25°C, laser current scan 15-23mA, detector output as shown

below.

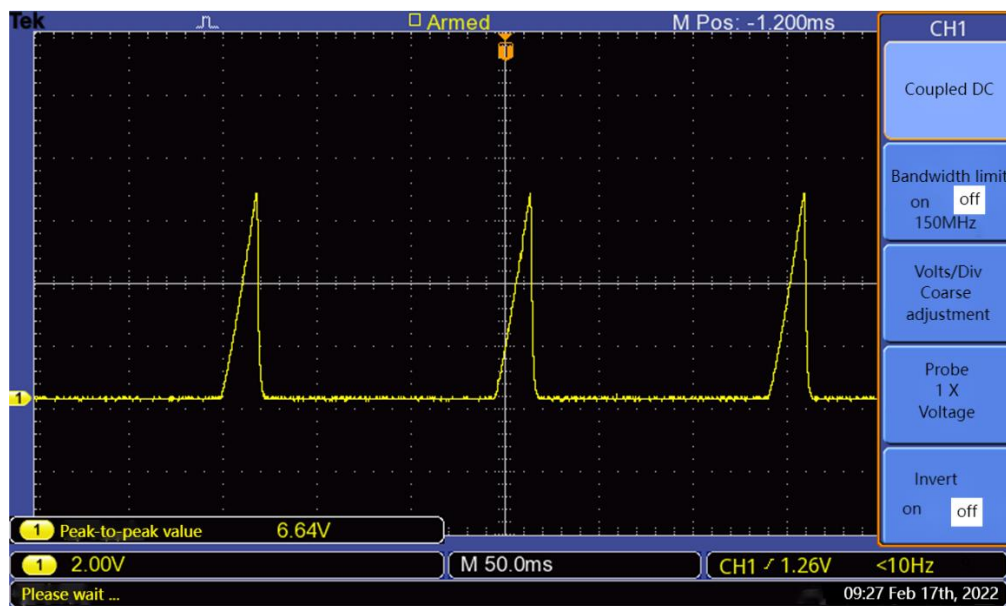

This detector has high detection accuracy at 972nm and can detect weak light  
 (tens of microwatts).