

InGaAs Large Area Photodetector, 800-1700nm (12MHz)



● Product Description

The InGaAs photodetector is a photodetector with a rated bandwidth and fixed gain, designed for detecting optical signals. The optical signal is input through the sensor surface, and the output is provided as a voltage via BNC. This product can measure optical signals in the wavelength range of 800nm to 1700nm. Detailed performance parameters are provided in the appendix table. Our photodetector housing includes mounting holes with a 1/4"-20 threaded pattern for easy installation and fixation. The housing also comes



with two different sizes of threaded rings, suitable for both industrial and research applications, enabling easy adaptation to external optical components such as filters, attenuators, lenses, and FC fiber optic adapters. This product includes a plastic dust cover. For specific installation instructions, please refer to Chapter 3. Each photodetector is provided with a $\pm 9V$ DC linear power supply, with an input rated voltage of 220VAC/50H

● Product features

Low noise, less than $\pm 1mV$ 、 Small overshoot, overshoot voltage less than 2.5% 、 Gain stability: Gain error less than 1% 、 Dark bias voltage output noise: Less than 1mV (rms)

● Part Number

MP-PDA10A7B4G-NIR

● Application area

Display panel testing 、 LED lighting flicker analysis 、 Toy light flicker frequency and power measurement 、 Gas analysis

● Core parameters

Wavelength	Bandwidth
800-1700nm	12MHz



● Dimension Drawing

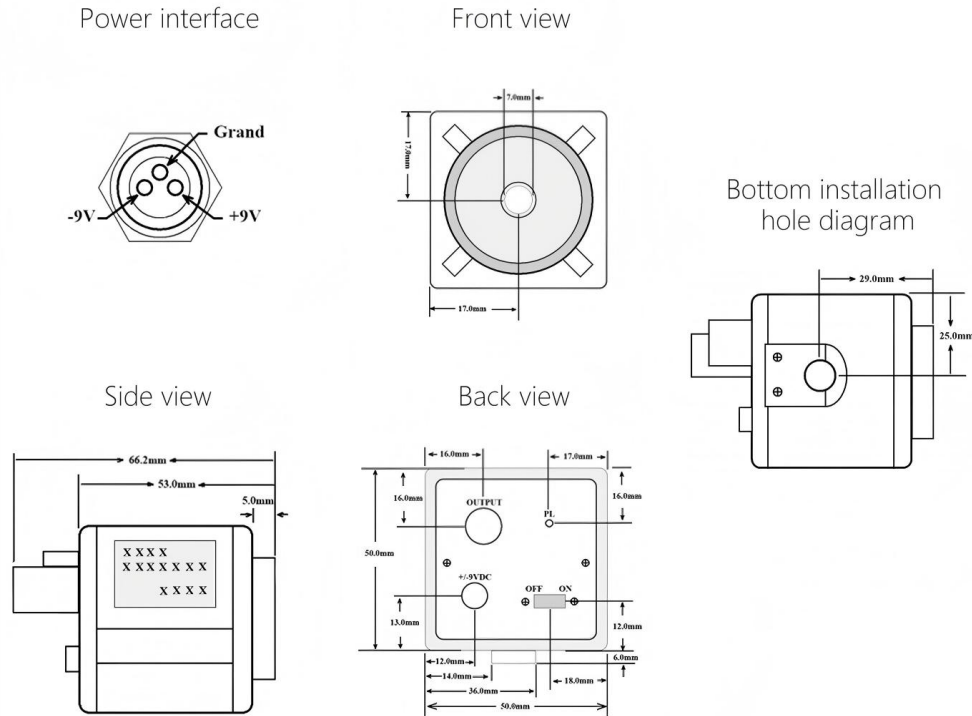

● General Parameters

parameter

PN#	MP-PDA M 005B-Si	MP-PDA M 36A5B6G-SI	MP-PDA M 20A6B4G- InGaAs
Electrical characteristics			
Input voltage	±9VDC, 60mA	±9VDG 100mA	±9VDC. 100mA
Probe	Silicon PIN	Silicon PIN	InGaAs PIN
Photosensitive surface	2.65mm * 2.65mm	3.6mm * 3.6mm	Diameters@2 mm



wavelength	400 nm - 1100 nm	320 nm - 1100 nm	800 nm - 1700 nm (Optional Extended 2600 nm)
Peak response	0.62A/W @850nm	0.6 A/W @960nm	0.9 A/W@1550nm
	43.6mV/ uW @850nm	1 mV/ nW @960nm	9mV/uW@1550nm
Saturation optical power	113pW@ 850nm (Hi-Z)	6uW @960nm (Hi-Z)	660 uW@1550nm (Hi-Z)
Bandwidth	DC • -5MHz	DC - 200kHz	DC - 5MHz
NEP	7.2 pW /4HZ ^{1/2}	2.2 pW /HZ ^{1/2}	64.5 pW /HZ ^{1/2}
Output noise (RMS)	700 uV	1 mV • typ	1.3 mV. typ
Dark current bias (MAX)	±5 mV	±1 mV	±5 mV
Rising edge/falling edge (10%-90%)	65 ns	1.7 us	68ns
Output voltage			
Hi-Z	0-SV (Hi-Z)	0-6V (Hi-Z)	0-6V (Hi-Z)
500	0 • 2.5V (50ohm)	0 • 25V (50ohm)	0 • 25V (50ohm)
Gain multiple			
Hi-Z	67.5 kV/A	1.68 MV/A	10 kV/A
50Q	33.8 kV/A	0.84 MV/A	5kV/A
Gain accuracy (typ)	±1%	±1%	±1%



Other parameters			
	Toggle switch	Toggle switch	Toggle switch
Output Interface	BNC	BNC	BNC
size	53*50*50mm	53*50*50mm	53*50*50mm
weight	150g	150g	150g
Operating temperature	10-50 degrees	10-50 degrees	10-50 degrees
Storage temperature	-25°C - 70°C	-25°C - 70°C	-25°C - 70°C

Reference for the amplified, & fixed gain model of InGaAs photodetector

model	wavelength	bandwidth	Rise time	Gain		RMS Noise	NEP	Sensing surface	Operating temperature	power supply
				Hi-Z Load	50Ω Load					
MP-PDA 10A8B4 G-NIR	800 - 1700 nm	DC - 140 MHz	2.5 nS	1*10 ⁴ V/A	5*10 ³ V/A	760 μV . typ	4.8*10 ⁻¹² W /√ HZ	φ1 mm	10-50 °C	Included (±9V)
MP-PDA 05A7B4 G-NIR	800 - 1700 nm	DC - 25M Hz	14 nS	1.2*10 ⁴ V/A	6*10 ³ V/A	1 mV . typ	1.9*10 ⁻¹¹ W /√ HZ	φ0.5 mm	10-50 °C	Included (±9V)



MP-PDA 10A7B4 G-NIR	800 - 1700 nm	DC - 12M Hz	29 nS	1*10 ⁴ V/A	5*10 ³ V/A	800 μV . typ	2.6*10 ⁻¹¹ W /√ HZ	φ1 mm	10-50 °C	Inclu ded (±9V)
MP-PDA 20A6B4 G-NIR	800 - 1700 nm	DC - 5MH z	70 nS	1*10 ⁴ V/A	5*10 ³ V/A	1.3 mV . typ	6.5*10 ⁻¹¹ W /√ HZ	φ2 mm	10-50 °C	Inclu ded (±9V)
MP-PDA 30A6B4 G-NIR	800 - 1700 nm	DC - 2MH z	175 nS	1*10 ⁴ V/A	5*10 ³ V/A	800 μV . typ	6.3*10 ⁻¹¹ W /√ HZ	φ3 mm	10-50 °C	Inclu ded (±9V)

Spectral sensitivity

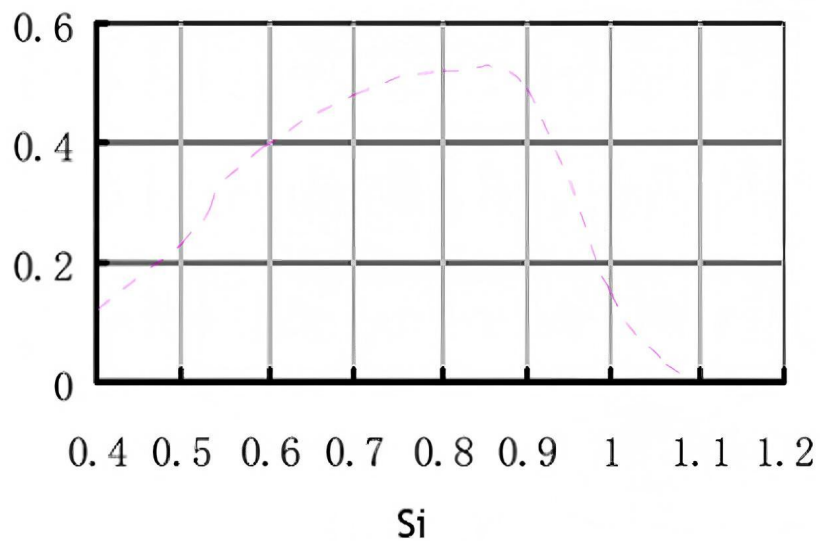

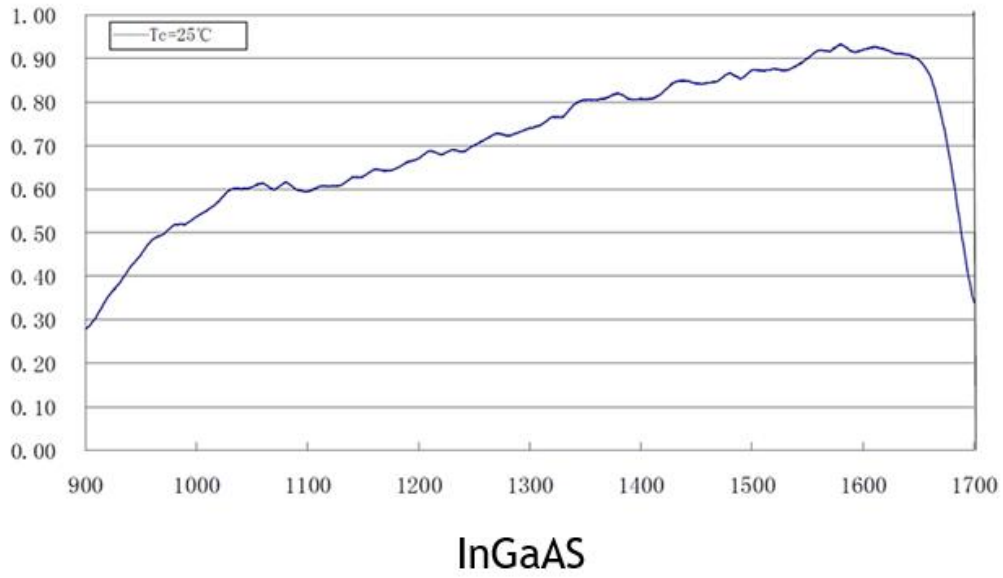

AC transfer characteristics

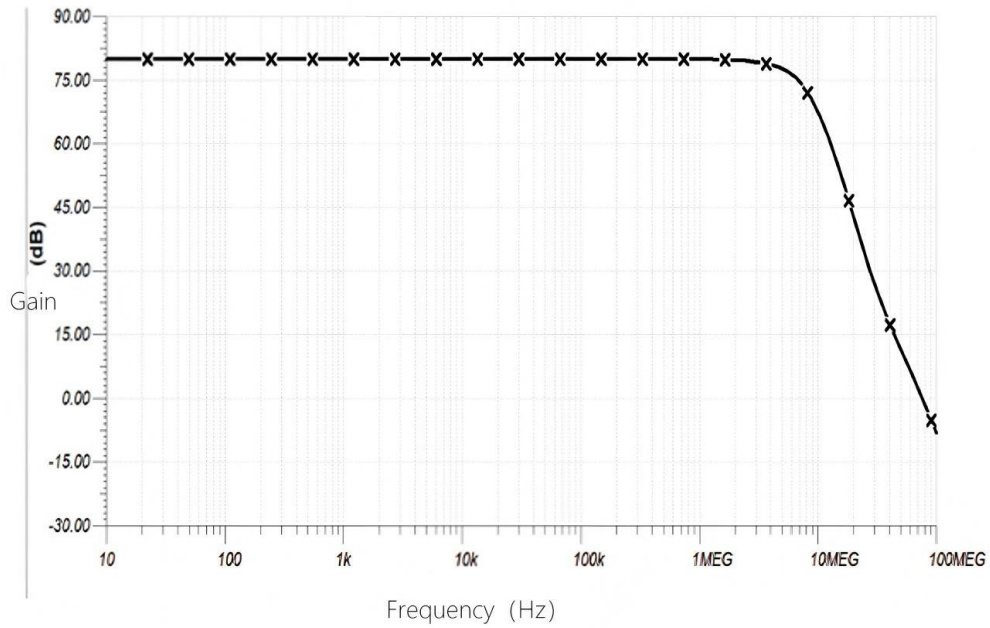

Appearance and installation

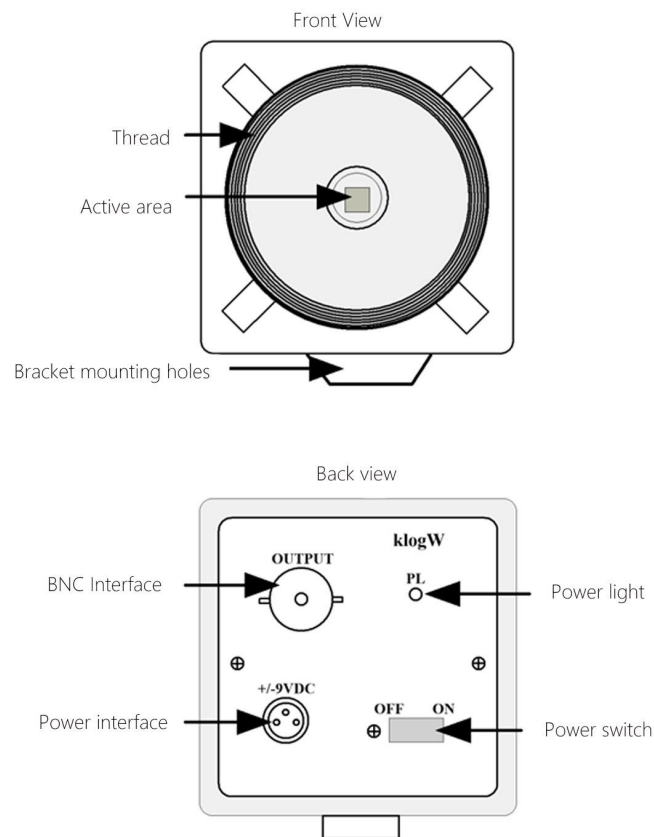

Test cases :

Test light source:

PN: PL-DFB-9672.4-B-A81-PA

SN:DO3431e-q2-Bo2-A19

Test conditions: 25°C, laser current scan 15-23mA, detector output as shown

below.

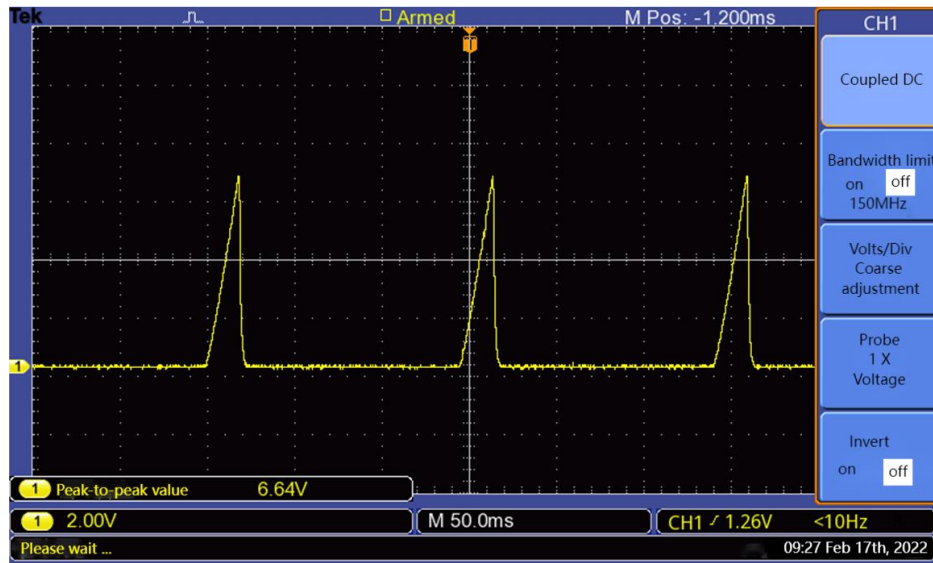

This detector has high detection accuracy at 972nm and can detect weak light (tens of microwatts).