

C-band variable gain fiber amplifier (gain range 30.5~42.5dB)



● Product Description

Idealphotonics' C-band variable gain fiber amplifier is a next generation variable gain fiber amplifier, which is a variable gain fiber amplifier with excellent performance and complete functions on the market today. It adopts the current excellent optical performance, advanced electronic technology, and complete software functions. Excellent transient suppression technology and thermal management control technology enable many complex optical functions to be realized. It is a versatile fiber



amplifier commonly used in the market today. The next generation variable gain fiber amplifier consists of a variable gain preamplifier (PA) and a variable gain power amplifier (BA), two-stage amplifier. The gain of the two-stage amplifier can be set independently within a certain range. There is an access connector between the two-stage amplifier, which can be used for mid-stage access, such as optical add/drop multiplexing module (OADM), dispersion compensation module (DCM) and other application optical modules. MP4700 is a version with mid-stage access. The product meets the communication technology requirements of C-Band 44-wavelength or 88-wavelength DWDM system and is widely used in long-distance and ultra-long-distance transmission networks. With its complete functions, it can be used as a line amplifier, preamplifier, power amplifier, and add-drop multiplexing amplifier.

● Product features

Next generation variable gain amplifier、 With intermediate access version、 AGC, APC, ACC working modes、 RS232 command interface、 Low power consumption、 1+1 power backup, supports hot swap

● Part Number

MP-EDFA-C-24-30.5-42.5-FA



● **Application area**

OADM optical add/drop multiplexing、 DCM ultra-long trunk line dispersion compensation、 ASON Intelligent Optical Network

● **Core parameters**

Wavelength Range	Gain Range
C band(1529.16nm-1563.86nm)	30.5-42.5dB

● **Dimension Drawing**

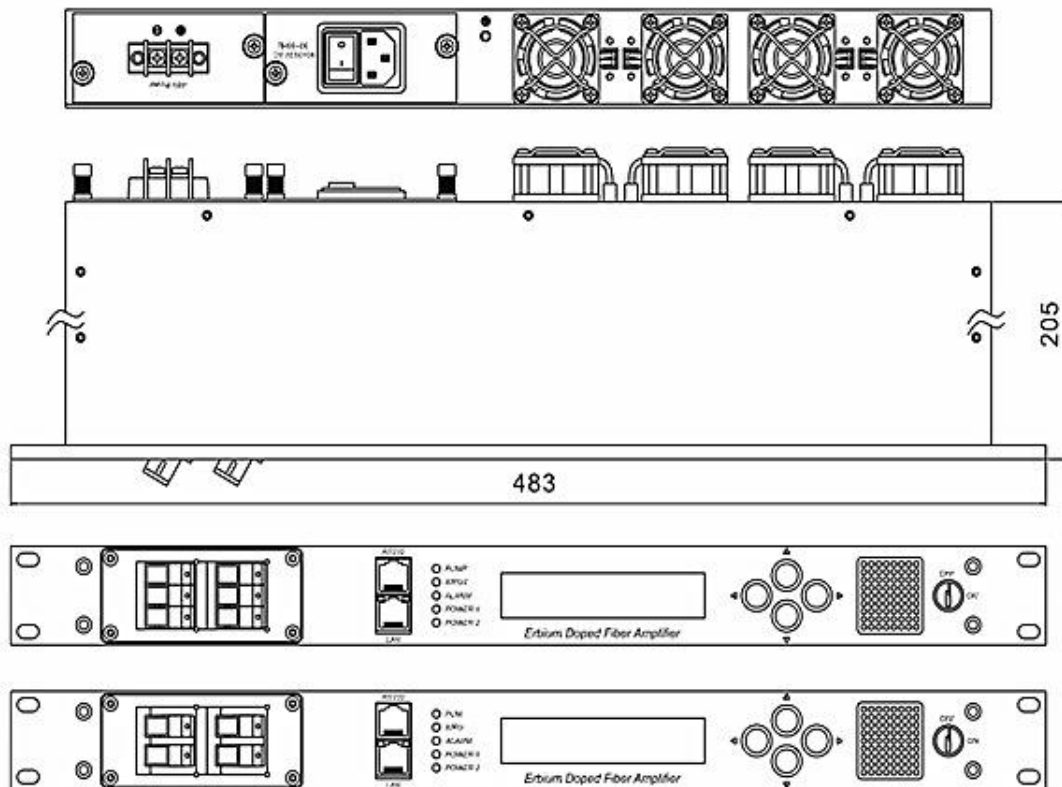



● General Parameters

performance		index			Replenish	
		Min	Type	Max		
Optical properties	Working wavelength range (λ)	(nm)	1529.16		1563.86	ITU 88CH
	Input optical power range ¹⁾	(dBm)	-35		+3	
			-35		+3	
			-40		0	
			-40		0	
	Gain range ²⁾	(dB)	13		21.5	
			18		30	
			23		35	
			29		41	
			12		24	
	Intermediate insertion loss range ³⁾	(dBm)	0		8	
			0		10	
			0		12	
	Maximum output optical power ⁴⁾	(dBm)			18.5	
					20	
					23	
				24		
Gain Flatness	(dB)		0.7	1.0	Peak-to-peak	
Noise Figure	(dB)		5.0	5.9	Max. gain	
Polarization Dependent Loss	(dB)			0.3		
Polarization Dependent Gain	(dB)			0.3		
Polarization Mode Dispersion	(ps)			0.3		
Pump light leakage	(dBm)			-30		



performance			index			Replenish
			Min	Type	Max	
Transient characteristics	Reflection loss ⁵⁾	(dB)	40			UPC
	Monitoring channel wavelength range	(nm)	1500	1510	1520	
	Transient suppression time	(μs)			500	
General Features	Transient overshoot	(dB)	1.5		1.0	16dB Add/Drop
	Transient gain change	(dB)			0.5	16dB Add/Drop
	SNMP network management interface		RJ45			
	Communication interface		RS232			
General Features	powered by	(V)	90		265	220VAC
			30		72	-48VDC
	Power consumption	(W)			25	
	Operating temperature	(°C)	0		70	
	Storage temperature	(°C)	-40		85	
	Working relative humidity	(%)	5		95	
	Dimensions (W) × (D) × (H)		483 × 205 × 44 (mm)			

Note:

1, 2, 3, 4: These optical performances are for a typical application and can be customized according to customer needs;

5: Optional APC, reflection loss > 50dB



Function, detection and alarm:

Function	Firmware Upgrade
	Automatic shutdown
	Variable Gain Control Mode (VGA) (with power limiting)
	The working mode of each level can be set independently (when there is intermediate access)
	Output Power Control Mode (APC)
	Pump current control mode (ACC)
	Eye-safe power mode
	Non-volatile event log
monitor	Total input power
	Total output power
	Backlight power (reflected light power)
	Pump status
	Chassis temperature
Alarm	Signal loss alarm
	Low output alarm
	Chassis temperature warning
	Pump temperature alarm
	Pump current alarm
	Excessive reflected optical power alarm (optional)

Photoelectric diagram:

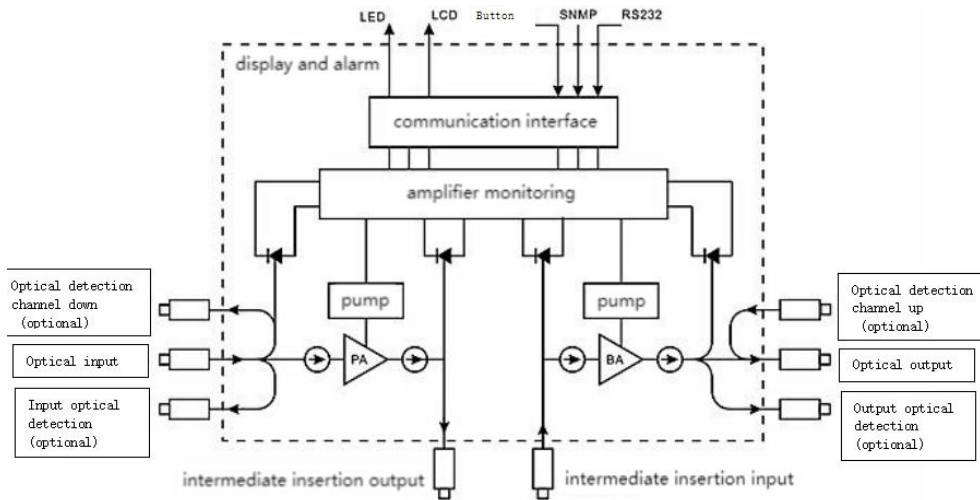

Model

model	Maximum output power (dBm)	Gain range typical value (dB)	Input power range typical value (dBm)	Intermediate insertion loss (dB)	Detection optical port mode	OSC optical port mode
MP-EDFA-C-18.5-12-21.5	18.5	13~21.5	+3~-30	0~8	none	none
MP-EDFA-C-18.5-18-28		18~28	+3~-35	0~10		
MP-EDFA-C-18.5-23-35		23~35	0~-35	0~12		
MP-EDFA-C-18.5-28.5-40.5		28.5~40.5	+3~-30	0~12		
MP-EDFA-C-20-18.5-30.5	20	18.5~30.5	+3~-35	0~12		
MP-EDFA-C-20-23-35		23~35	0~-35			
MP-EDFA-C-20-29-41		29~41	+3~-35			
MP-EDFA-C-23-19-31	23	19~31	0~-35	0~12		
MP-EDFA-C-23-25-37		25~37	0~-37			
MP-EDFA-C-23-29-41		29~41	0~-40			
MP-EDFA-C-24-25-37	24	25~37	0~-37	0~12		
MP-EDFA-C-24-30.5-42.5		30.5~42.5	0~-40			



Remark:

1) Detection optical port mode options: 1. MO (with output monitoring optical port); 2. MI (with input monitoring optical port); 3. MIO (with input and output monitoring optical port)

2) Optical management channel OSC optical port mode options: 1. OD (OSC / Drop); 2. OA (OSC / Add); 3. ODA (OSC / Drop & Add)