

C-Band variable gain fiber amplifier (gain range 19~31dB)



● Product Description

Idealphotonics' C-band variable gain fiber amplifier is a next generation variable gain fiber amplifier, which is a variable gain fiber amplifier with excellent performance and complete functions on the market today. It adopts the current excellent optical performance, advanced electronic technology, and complete software functions. Excellent transient suppression technology and thermal management control technology enable many complex optical functions to be realized. It is a versatile fiber amplifier commonly used in the market today. The next generation variable



gain fiber amplifier consists of a variable gain preamplifier (PA) and a variable gain power amplifier (BA), two-stage amplifier. The gain of the two-stage amplifier can be set independently within a certain range. There is an access connector between the two-stage amplifier, which can be used for mid-stage access, such as optical add/drop multiplexing module (OADM), dispersion compensation module (DCM) and other application optical modules. MP4700 is a version with mid-stage access. The product meets the communication technology requirements of C-Band 44-wavelength or 88-wavelength DWDM system and is widely used in long-distance and ultra-long-distance transmission networks. With its complete functions, it can be used as a line amplifier, preamplifier, power amplifier, and add-drop multiplexing amplifier.

● Product features

Next generation variable gain amplifier、 With intermediate access version、 Adopt digital control technology that adapts to thermal management 、 Intermediate version can be set up as separate preamplifier and power amplifier 、 Saturated output power can be selected as 18dBm, 20dBm, 23dBm、 AGC, APC, ACC working modes、 SNMP network management function、 RS232 command interface、 Optional optical monitoring channel OSC Add/Drop、 Carrier-level security, reliability and network management



functions、 Low power consumption、 1+1 power backup, supports hot swap、 Excellent performance-price ratio in the industry

● Part Number

MP-EDFA-C-23-19-31-FA

● Application area

OADM optical add/drop multiplexing、 DCM ultra-long trunk line dispersion compensation、 ASON Intelligent Optical Network、 ROADM reconfigurable optical add/drop multiplexing 、 Long-distance and ultra-long-distance networks between cities、 Line amplifier, preamplifier, power amplifier, add/drop multiplexer amplifier

● Core parameters

Wavelength Range	Gain Range
C band(1529.16nm-1563.86nm)	19~31dB

● Dimension Drawing

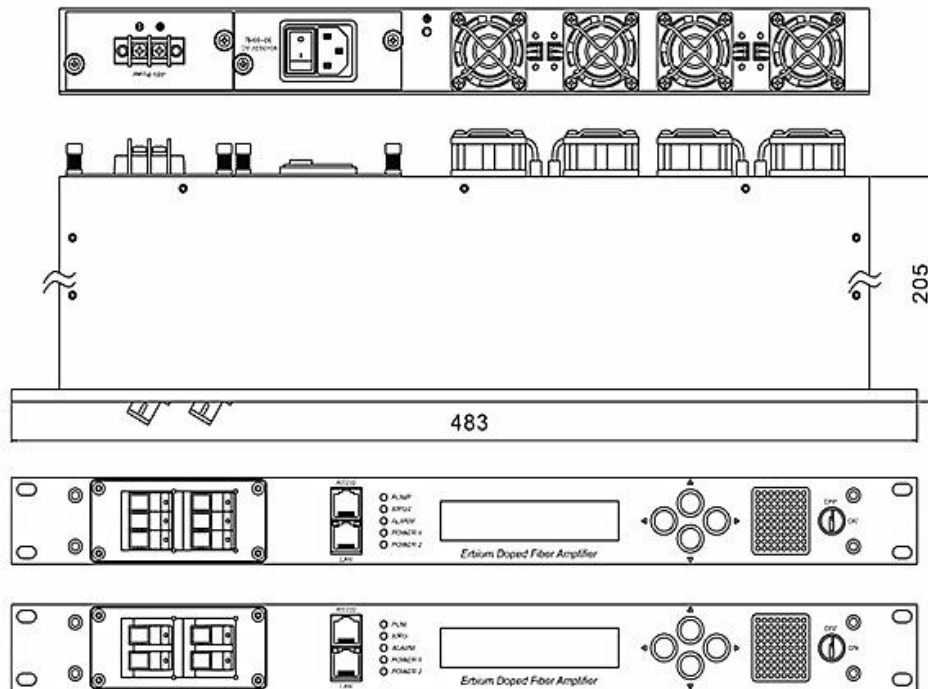

● General Parameters

performance		index			Replenish	
		Min	Type	Max		
Optical properties	Working wavelength range (λ)	(nm)	1529.16		1563.86	ITU 88CH
	Input optical power range ¹⁾	(dBm)	-35		+3	
			-35		+3	
			-40		0	
			-40		0	
	Gain range ²⁾	(dB)	13		21.5	
			18		30	
23				35		
29				41		
12				24		
Intermediate insertion	(dBm)	0		8		



performance		index			Replenish		
		Min	Type	Max			
	loss range ³⁾		0		10		
			0		12		
	Maximum output optical power ⁴⁾	(dBm)				18.5	
						20	
						23	
						24	
	Gain Flatness	(dB)		0.7	1.0	Peak-to-peak	
	Noise Figure	(dB)		5.0	5.9	Max. gain	
	Polarization Dependent Loss	(dB)				0.3	
	Polarization Dependent Gain	(dB)				0.3	
	Polarization Mode Dispersion	(ps)				0.3	
	Pump light leakage	(dBm)				-30	
	Reflection loss ⁵⁾	(dB)	40			UPC	
Monitoring channel wavelength range	(nm)	1500	1510	1520			
Transient characteristics	Transient suppression time	(μ s)			500		
	Transient overshoot	(dB)	1.5		1.0	16dB Add/Drop	
	Transient gain change	(dB)			0.5	16dB Add/Drop	
General Features	SNMP network management interface		RJ45				
	Communication interface		RS232				
	powered by	(V)	90		265	220VAC	
			30		72	-48VDC	



performance		index			Replenish
		Min	Type	Max	
Power consumption	(W)			25	
Operating temperature	(°C)	0		70	
Storage temperature	(°C)	-40		85	
Working relative humidity	(%)	5		95	
Dimensions (W) × (D) × (H)		483 × 205 × 44 (mm)			

Note:

1, 2, 3, 4: These optical performances are for a typical application and can be customized according to customer needs;

5: Optional APC, reflection loss > 50dB

Function, detection and alarm:

	Firmware Upgrade
	Automatic shutdown
	Variable Gain Control Mode (VGA) (with power limiting)
	The working mode of each level can be set independently (when there is intermediate access)
	Output Power Control Mode (APC)
	Pump current control mode (ACC)
	Eye-safe power mode
	Non-volatile event log
monitor	Total input power
	Total output power
	Backlight power (reflected light power)
	Pump status
	Chassis temperature



Function	Firmware Upgrade
Alarm	Signal loss alarm
	Low output alarm
	Chassis temperature warning
	Pump temperature alarm
	Pump current alarm
	Excessive reflected optical power alarm (optional)

Photoelectric diagram:

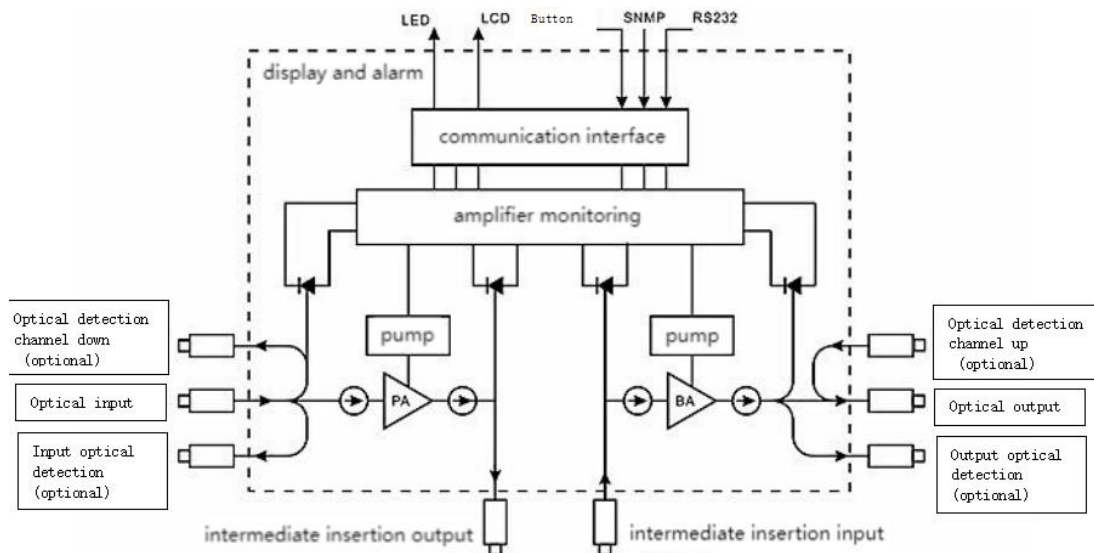

Model

model	Maximum output power (dBm)	Gain range typical value (dB)	Input power range typical value (dBm)	Intermediate insertion loss (dB)	Detection on optical port mode	OSC optical port mode
MP-EDFA-C-18.5-12-21.5	18.5	13~21.5	+3~-30	0~8	none	none



model	Maximum output power (dBm)	Gain range typical value (dB)	Input power range typical value (dBm)	Intermediate insertion loss (dB)	Detection optical port mode	OSC optical port mode
MP-EDFA-C-18.5-18-28		18~28	+3~-35	0~10		
MP-EDFA-C-18.5-23-35		23~35	0~-35	0~12		
MP-EDFA-C-18.5-28.5-40.5		28.5~40.5	+3~-30	0~12		
MP-EDFA-C-20-18.5-30.5	20	18.5~30.5	+3~-35	0~12		
MP-EDFA-C-20-23-35		23~35	0~-35			
MP-EDFA-C-20-29-41		29~41	+3~-35			
MP-EDFA-C-23-19-31	23	19~31	0~-35	0~12		
MP-EDFA-C-23-25-37		25~37	0~-37			
MP-EDFA-C-23-29-41		29~41	0~-40			
MP-EDFA-C-24-25-37	24	25~37	0~-37	0~12		
MP-EDFA-C-24-30.5-42.5		30.5~42.5	0~-40			

Remark:

1) Detection optical port mode options: 1. MO (with output monitoring optical port); 2. MI (with input monitoring optical port); 3. MIO (with input and output monitoring optical port)

2) Optical management channel OSC optical port mode options: 1. OD (OSC / Drop); 2. OA (OSC / Add); 3. ODA (OSC / Drop & Add)