

## 1.5G InGaAs Balance Photodetector

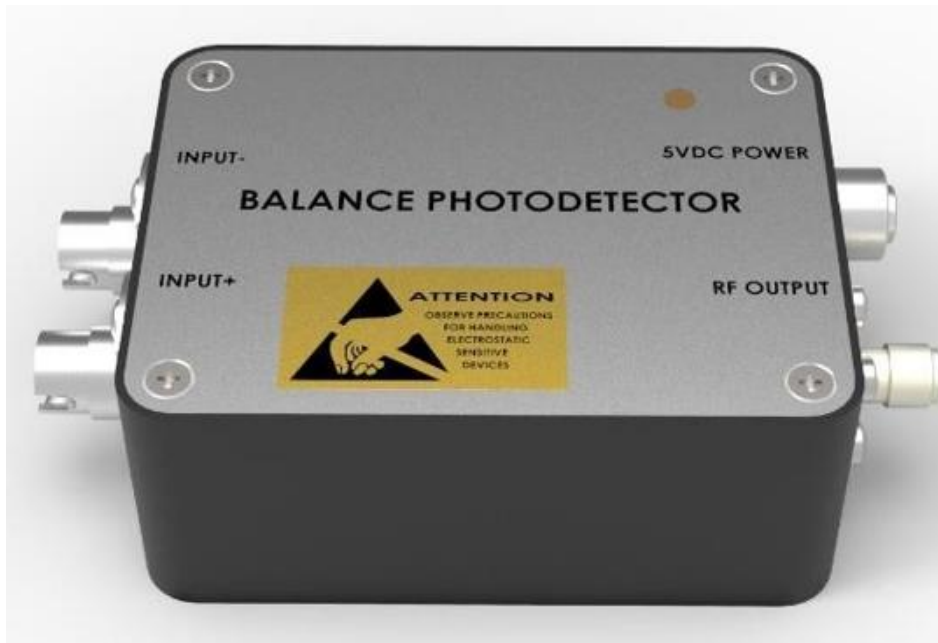

- **Product Description**

The high-speed low-noise photoelectric Balance Photodetector integrates two matched low-noise analog PIN detectors, a low-noise broadband transimpedance amplifier and an ultra-low noise power supply. It has the characteristics of high gain, high sensitivity, high bandwidth, low noise, high common mode rejection ratio, etc. It can effectively reduce the common mode noise of the signal and improve the signal-to-noise ratio of the system.



## ● Product features

Low noise、 High gain、 High bandwidth、 Compact structure、 Built-in low noise isolated power supply

## ● Part Number

MP-BPD-M-I-1500-F/S-A

## ● Application area

Distributed fiber optic sensing、 Laser wind radar、 Optical coherence tomography、 Spectral measurement、 Nanosecond optical pulse detection

## ● Core parameters

Wavelength	Bandwidth
800-1700nm	1.5GHz

## ● General Parameters

Parameters

Detector type	InGaAs										Unit
Wavelength	800~1700										nm
Bandwidth	100 M	200 M	300 M	400 M	500 M	800 M	1G	1.5 G	2G	2.5 G	Hz



Detector responsivity	0.95	0.95	0.95	0.95	0.95	0.95	0.95	0.95	0.95	0.95	0.95	A/W@ 1550nm
Transimpedance gain	30K	30K	30K	10K	5K	30K	30K	30K	15K	15K		V/A
Maximum input optical power	140	140	140	420	840	140	140	140	280	280		μW
NEP	5	5	5	7	7	9	9	9	9	9		pW/Sqrt(Hz)
Output impedance	50	50	50	50	50	50	50	50	50	50		Ω
Output coupling mode	DC/AC	DC/AC	DC/AC	DC/AC	DC	AC	AC	AC	AC	AC	DC	
Supply voltage	5	5	5	5	5	12	12	12	12	12		V
Supply current	0.3(max)	0.3(max)	0.3(max)	0.3(max)	0.3(max)	0.3(max)	0.3(max)	0.3(max)	0.3(max)	0.3(max)		A
Optical input	FC/APC (Free space light optional)											
RF output	SMA											

## Test results:

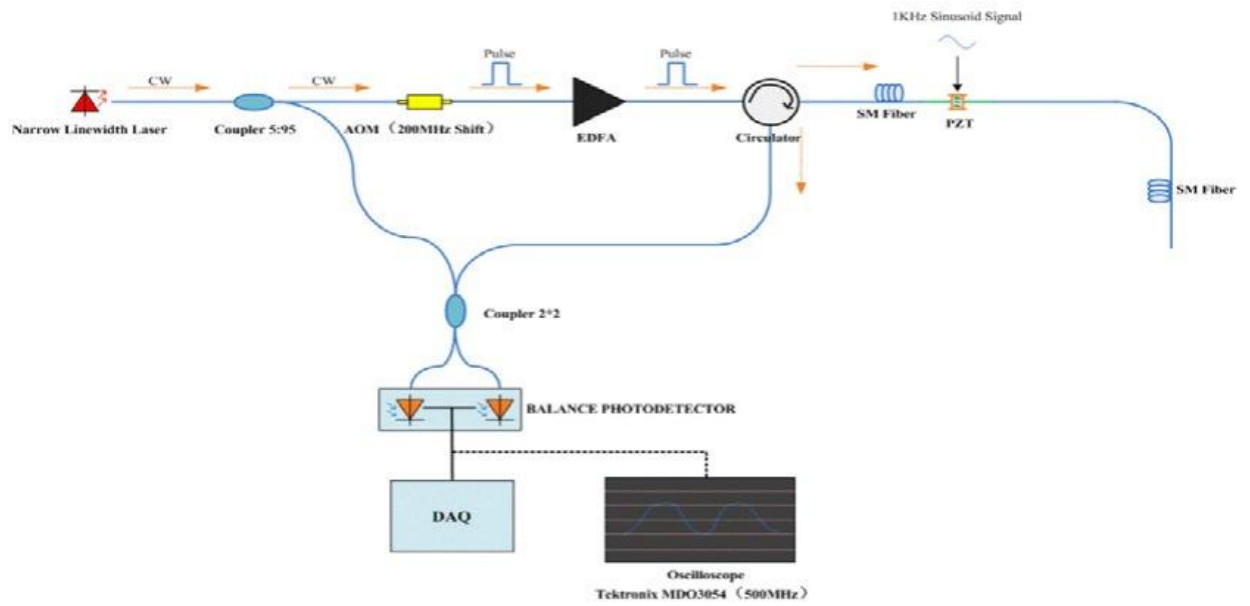

## Coherent Detection Distributed Fiber Optic Sensing:

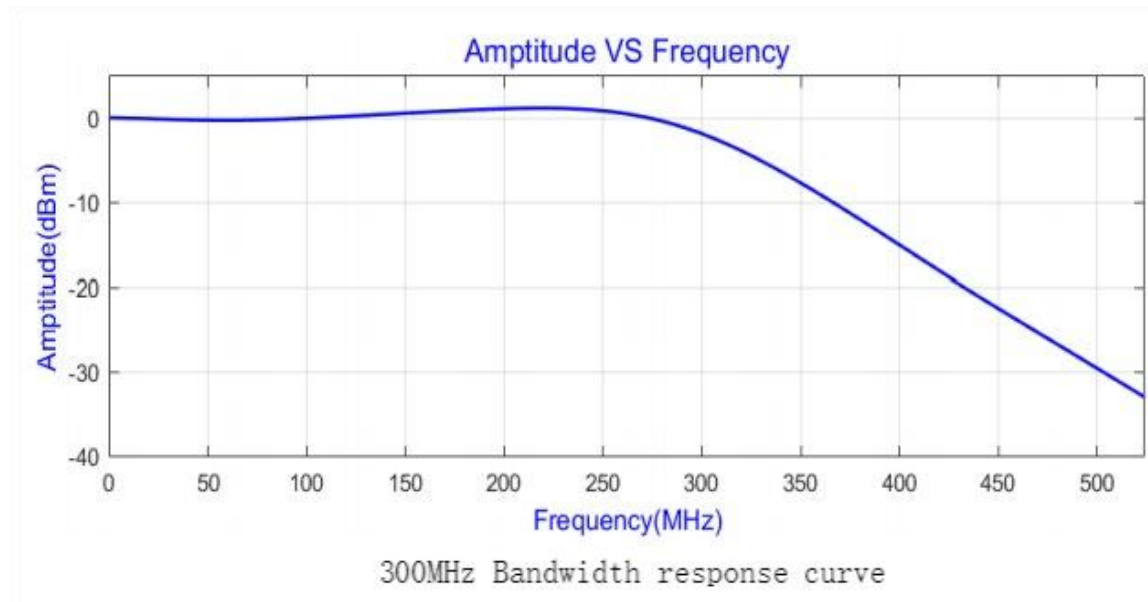

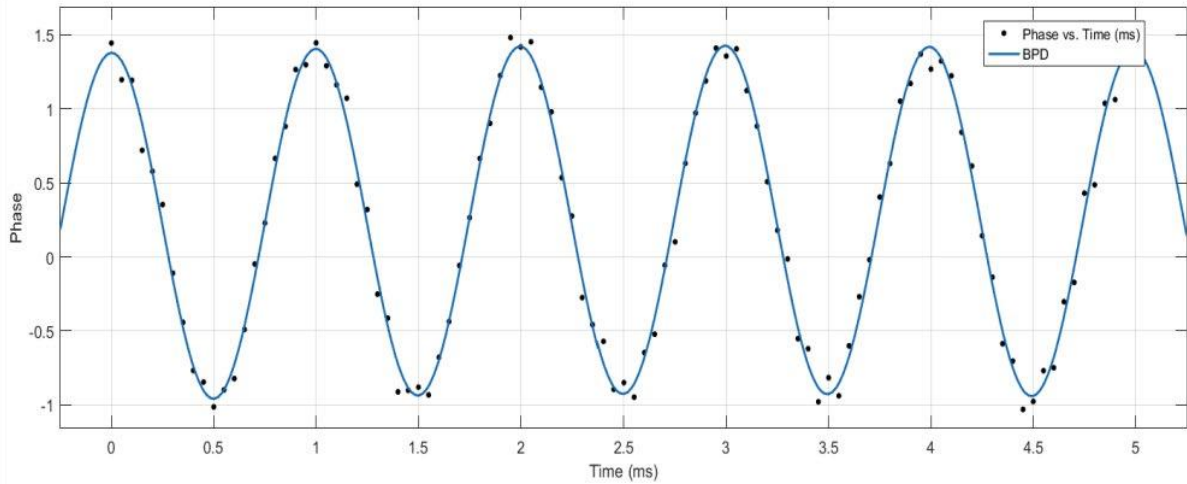

PZT vibration point demodulation phase on optical fiber (1kHz)