

630 nm PM Fiber Connectors/Patch Cables



● Product Description

These polarization-maintaining fiber patch cords offered by Idealphotonics feature high-quality, narrow-pin ceramic FC/APC connectors on both ends. Produced in our facilities, each patch cord is individually tested at the test wavelengths listed on the Specs tab to ensure extinction ratio and low back reflection (return loss) when connecting fiber to fiber. These patch cords are available in stock with a high-quality polish that guarantees a typical return loss of over 60 dB. The test data table provides extinction ratio and insertion loss tests for each patch cord. Each patch cord comes with two protective caps covering the ends to prevent dust or other contaminants from falling into the ferrule end face. We also sell CAPF plastic fiber caps and CAPFM

metal threaded fiber caps to protect FC/PC terminations separately. If you don't find the product you need in our stock patch cords, we also offers custom patch cords that can be shipped the same day.

● Product features

Slow-axis aligned、 Polarization-maintaining fiber with a pair of FC/APC connectors、 Wavelength range 400-2200nm、 Narrow plug (2 mm) and slow-axis aligned、 Typical 60 dB return loss、 Ceramic ferrule, angled 8° (APC)、 Ø3 mm outer protective covering、 Custom patch cables available

● Part Number

MP-FOJ-630-2-2-PA

● Application area

Fiber optic communication system、 Fiber optic access network、 Fiber optic data transmission、 Fiber optic CATV、 Local area network (LAN)、 Test equipment、 Fiber optic sensor

● Core parameters

Operating Wavelength	Fiber Type
620-850nm	PM-S405-XP

● General Parameters

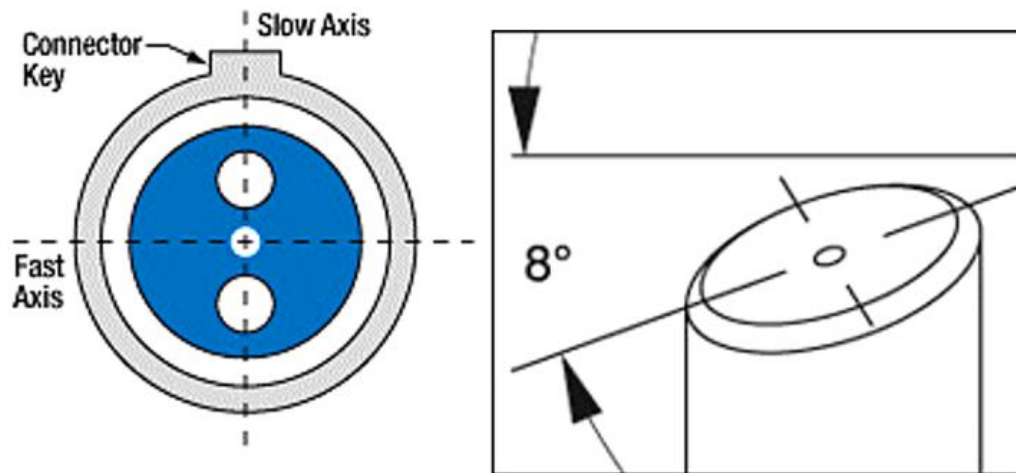

Parameter

PN#	MP-FOJ-40	MP-FOJ-488	MP-FOJ-630	MP-FOJ-78	MP-FOJ-9
	5-2-1-PA	-2-1-PA	-2-1-PA	0-2-1-PA	80-2-1-PA
Test wavelength	405 nm	488 nm	630 nm	780 nm	980 nm
Operating wavelength	400 - 680 nm	460 - 700 nm	620 - 850 nm	770 - 1100 nm	970 - 1550 nm
Cut-off wavelength	380 ± 20 nm	420 ± 30 nm	570 ± 50 nm	710 ± 60 nm	920 ± 50 nm
Fiber type	PM-S405-XP (Panda)	PM460-HP (Panda)	PM630-HP (Panda)	PM780-H P (Panda)	PM980-X P (Panda)
Maximum insertion loss a	1.5 dB	1.5 dB	1.2 dB	1.0 dB	0.7 dB



Minimum extinction ratio a	15 dB	18 dB	20 dB	20 dB	22 dB
Mode field diameter b	3.6 ± 0.5 um @ 405nm	3.4 um @ 488nm	4.2 um @ 630nm	4.9 um @ 780nm	6.6 ± 0.7 um @ 980nm
Numerical aperture c	0.12	0.12	0.12	0.12	0.12
Return loss a	60 dB Typical				
Fiber connector	FC/APC				
Connector groove width	2.00 ± 0.02 mm				
Alignment method	Narrow Key Aligned to Slow Axis				
Fiber length	1.0 +0.075/-0 m for Item Numbers Ending in -1				
Loose tube type	2.0 +0.075/-0 m for Item Numbers Ending in -2				
Operating temperature	5.0 +0.075/-0 m for Item Numbers Ending in -5				
Storage temperature	10.0 +0.075/-0 m for Item Numbers Ending in -10				
Cut-off wavelength	900um/2mm/3mm armor can be choose				
Fiber type	0 to 70 °C				
Maximum insertion	-45 to 85 °C				



loss a

PN#	MP-FOJ-10 64-2-1-PA	MP-FOJ-13 10-2-1-PA	MP-FOJ-15 50-2-1-PA	MP-FOJ-20 00-2-1-PA
Test wavelength	1064 nm	1310 nm	1550 nm	2000 nm
Operating wavelength	970 - 1550 nm	1270 - 1625 nm	1440 - 1625 nm	1850 - 2200 nm
Cut-off wavelength	920 ±50 nm	1200 ±70 nm	1370 ±70 nm	1720 ±80 nm
Fiber type	PM980-XP(Panda)	PM1300-X P(Panda)	PM1550-XP (Panda)	PM2000(Panda)
Maximum insertion loss a	0.7 dB	0.5 dB	0.5 dB	0.5 dB
Minimum extinction ratio a	22 dB	23 dB	23 dB	23 dB
Mode field diameter b	7.7 um@ 1064 nm	9.3 ±0.5 um @ 1300 nm	9.9 ±0.5 um @ 1550 nm	8.6 um @ 2000 nm
Numerical aperture c	0.12	0.13	0.125	0.2
Return loss a	60 dB Typical			
Fiber connector	FC/APC			
Connector groove width	2.00 mm ±0.02			
Alignment method	Narrow Key Aligned to Slow Axis			

Fiber length	1.0 +0.075/-0 m for Item NumbersEnding in -1
	2.0 +0.075/-0 m for Item NumbersEnding in -2
	5.0 +0.075/-0 m for Item NumbersEnding in -5
	10.0 +0.075/-0 m for Item NumbersEnding in -10
loose tube type	900um 2mm 3mm Armor is optional
Operating temperature	0 to 70 °C
storage temperature	-45 to 85°C

Note:

- a. Measured at the test wavelength.
- b. Mode field diameter (MFD) is a nominal value. The diameter at the $1/e^2$ power position in the near field.
- c. Numerical aperture (NA) is a nominal value.

1550PM Fiber Optic Patch Cord Experimental Test:

1. End-face inspection

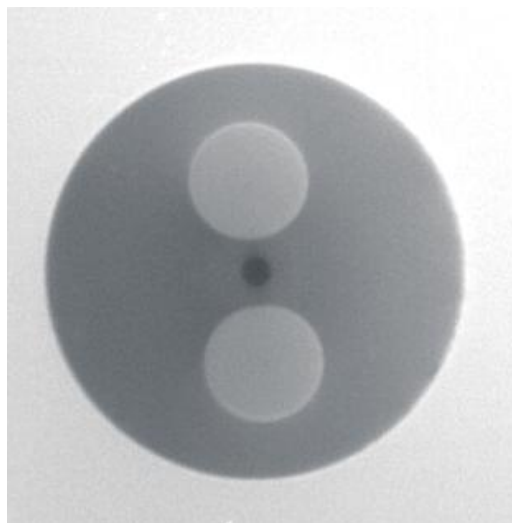



2. IL test

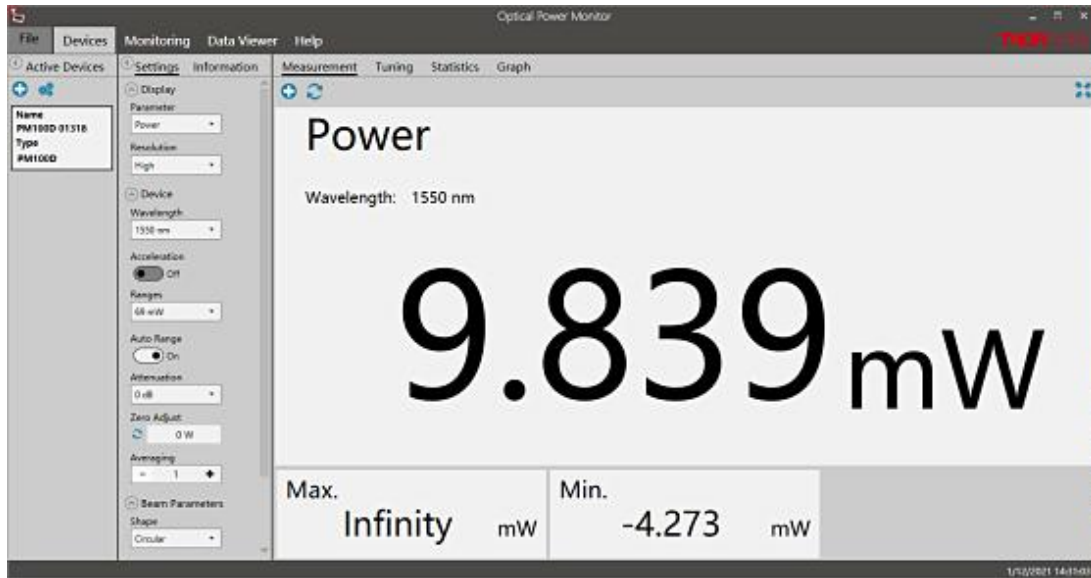

Laser power before connection

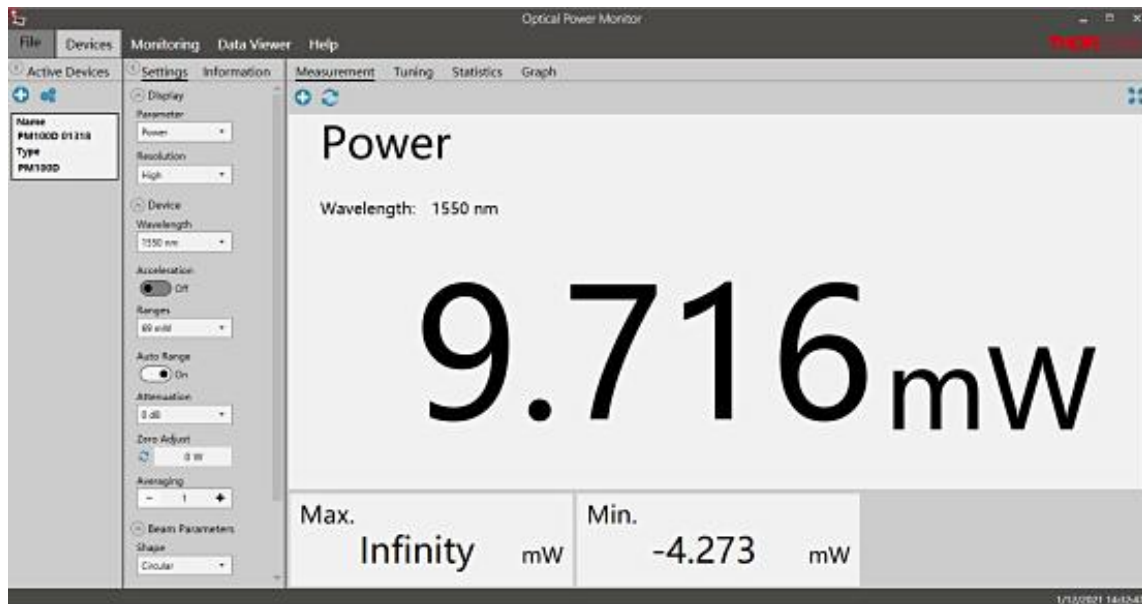

Power after connecting the fiber optic patch cord



3. Extinction Ratio Testing

Measurement:

PER [dB]:	64.8
Lin. PER [dB]:	40.3
Lin. V:	10786
Beam Dec.:	23.6
DOP [%]:	100.0
Intensity [%]:	0.5

Fiber PER-Measurement:

η [°]:	-0.1
$\Delta\eta$ [°]:	0.0
rel. ϕ [°]:	-5.1
Mean PER [dB]:	57.6
Min PER [dB]:	56.2
Min Ext. Ratio V:	1:419785

comment is empty

Adjustment quality [%]:

0 90 99 99.9 99.99

Schäfter + Kirchhoff
12.01.2021, 13:27:31

Laser Direct Testing

Measurement:

PER [dB]:	37.3
Lin. PER [dB]:	32.0
Lin. V:	1582
Beam Dec.:	14.8
DOP [%]:	100.0
Intensity [%]:	1.0

Fiber PER-Measurement:

η [°]:	-0.8
$\Delta\eta$ [°]:	0.0
rel. ϕ [°]:	-11.6
Mean PER [dB]:	37.3
Min PER [dB]:	37.2
Min Ext. Ratio V:	1:5204

comment is empty

Adjustment quality [%]:

0 90 99 99.9 99.99

Schäfter + Kirchhoff
 12.01.2021, 13:29:41

After Connecting Optical Fiber Patch Cord