

## 600-1750nm InGaAs quadrant photodiode

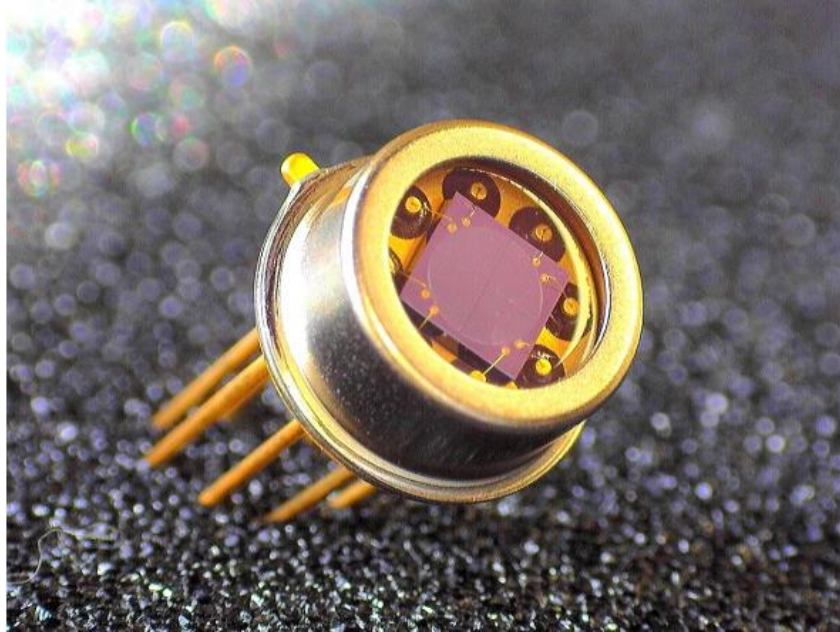

- **Product Description**

The MP-QPD-B-I-W3 series is a product line with high sensitivity and high reliability, making it ideal for optical communication equipment. This model is also available with custom packaging options.

- **Product features**

High-speed response - 1.0GHz、 TO-5 metal can package、 Effective area:  
3.0mm / High sensitivity、 Spectral range: 600nm - 1750nm



- **Part Number**

MP-QPD-B-I-W3

- **Application area**

High-speed optical communication、 Industrial control、 Optical switches、  
 Radar、 Medical

- **Core parameters**

Wavelength	Responsivity	Effective Area
600-1750nm	0.55A/W@1330nm	3mm

- **General Parameters**

Silicon and InGaAs Quadrant Photodiodes

(“Quads” or quadrant photodiodes)A “quadrant” or quadrant photodiode (QPD) is a segmented photodiode position sensing detector (PSD, AKA position sensing diode) with four planar diffused photodiode elements that are monolithic or on the same silicon or InGaAs chip. Marktech Photonics Quad Photodiodes feature low dark current, high resolution or accuracy, high precision, low noise high response (high S/N ratio), wide spectral range, good frequency bandwidth, excellent dynamic range, min. element pitch, low operating voltage, high shunt resistance, and large active area.

Two-segment, dual-element or dual-unit photodiodes are another type of position sensing device that are often incorporated into alignment or positioning systems. While quadrant photodiodes can sense position along two dimensions or X and Y axes, dual-element photodiodes align or position along one dimension or axis.

Marktech' s Quad Photodiode Arrays or Quad Detectors provide excellent performance in laser alignment and nanopositioning applications. Quadrant photodiodes (QPDs) or quadrant position sensitive detectors typically have resolutions down to 10 nm using beams with optical powers of 10 to 100 microwatts (MÉKYNEN). Quadrants can be used in laser alignment autocollimators, optical trackers, scanning probe microscopes, stage positioners, surface profilers, mask aligners, beam centering systems, space solar sensors, ellipsometers, optical tweezers, tilt sensors, high-precision displacement sensors, and other ultra-precision positioning applications. The fast response and wide operating bandwidth of QPDs have made these positioning devices dominant in the atomic force microscopy (AFM) industry (Chien et al.). Satellite communication systems can also benefit from quadrant photodiodes. For example, quadrant photodiodes are a key component in the front-end devices of quadrant photoreceivers (QPRs) used for inter-satellite laser interferometry.



**InGaAs Quadrant PIN Photodiode 600 to 1750nm sensitivity.**

Both bi-element and quadrant photodiodes are photodiode arrays (PDAs) with two (1X2) and four (2X2) elements, respectively. Bi and quad PDs are suitable for alignment or position sensing over a small range of beam displacement or position. For longer range laser or beam position sensing, longer multi-element photodiode arrays are required. Marktech Optoelectronics also manufactures multi-element linear (one-dimensional, 1D) and area (two-dimensional, 2D) photodiode arrays with many segments for dispersive spectroscopy, refraction measurement, distance or range finding (triangulated position sensing), interferometry, and particle analyzers. Most photodiode array applications require custom designed arrays and OEM integration, which is one of Marktech's



industry-leading capabilities. Marktech's detector experts design and manufacture photodiode arrays with 2, 4, 16, 20, 32, 64 and more elements.

Our InGaAs quadrant photodiodes and photodiode arrays have a wavelength sensitivity range of 600nm–2600nm. Our silicon quadrant photodiodes and photodiode arrays have a wavelength sensitivity range of 250nm to 1100nm.

These chips can be packaged individually in a variety of hermetic TO packages or integrated into custom packages (PLCC, COB, ATLAS hermetic SMD, ceramic carrier, etc.) to suit your specific application and pin design specifications.

### Absolute Maximum Ratings (Ta=25°C):

Parameters	Symbol	Value	Unit
Effective Area	$\Phi$	3.0	mm
Operating Temperature Range	T <sub>opr</sub>	40 to +85	°C
Storage Temperature Range	T <sub>stg</sub>	40 to +125	°C

### Photonic Parameters (Ta = 25°C):

Parameters	Symbol	Condition	Min.	Typ.	Max	Unit
Dark Current	I <sub>D</sub>	V <sub>R</sub> =0V	--	0.13	--	nA
Sensitivity Range	$\lambda$	V <sub>R</sub> =0V	600	--	1750	nm
Peak Wavelength	$\lambda$	V <sub>R</sub> =0V	--	1600	--	nm
Crosstalk	CT	V <sub>R</sub> =0V, $\lambda$ =1600nm	--	2	5	%
Responsivity	R	$\lambda$ =1330nm	--	0.55	--	A/W



Parameters	Symbol	Condition	Min.	Typ.	Max	Unit
		$\lambda=1600\text{nm}$	0.90	0.95	--	
Rise Time @ 1330nm	$T_R$	$V_R=2\text{V}; R_L=50\Omega$	--	8	--	ns
Parallel Resistance	$R_{SH}$	$V_R=10\text{mV}, -10\text{mV}$	--	1.43	--	$M\Omega$
Capacitance	$C$	$V_R=0\text{V}; 1\text{MHz}$	--	107	--	pF

\*1: The device specifications are (per element)

## Dimensions

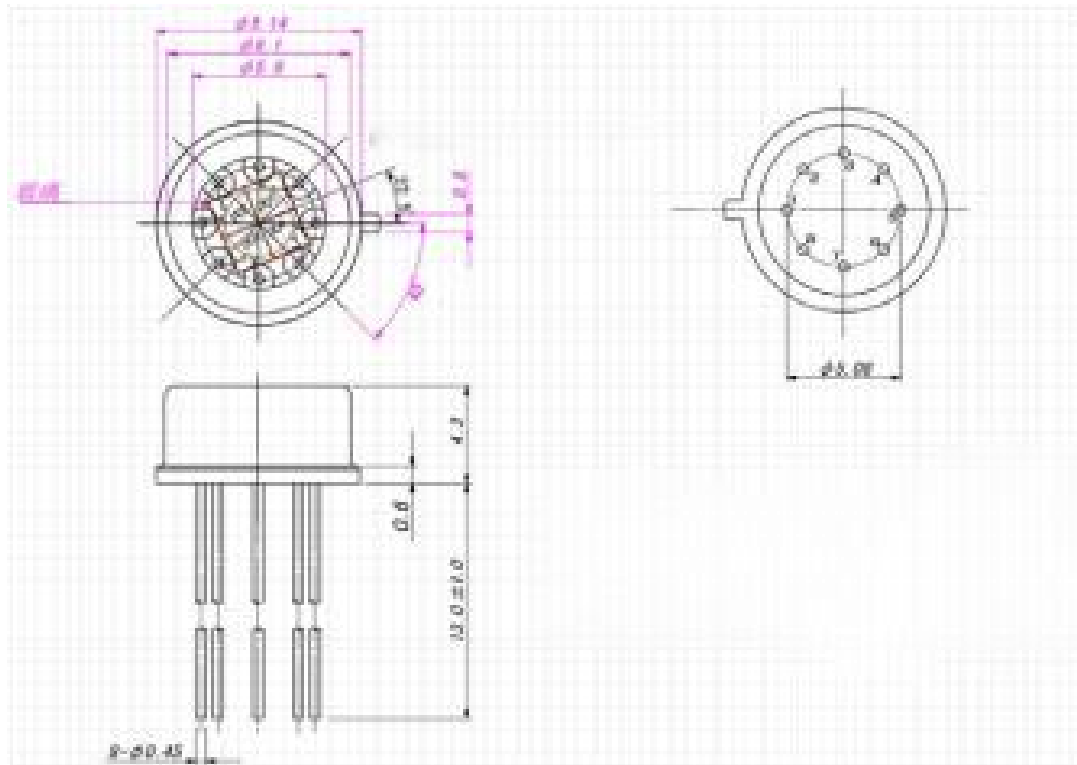

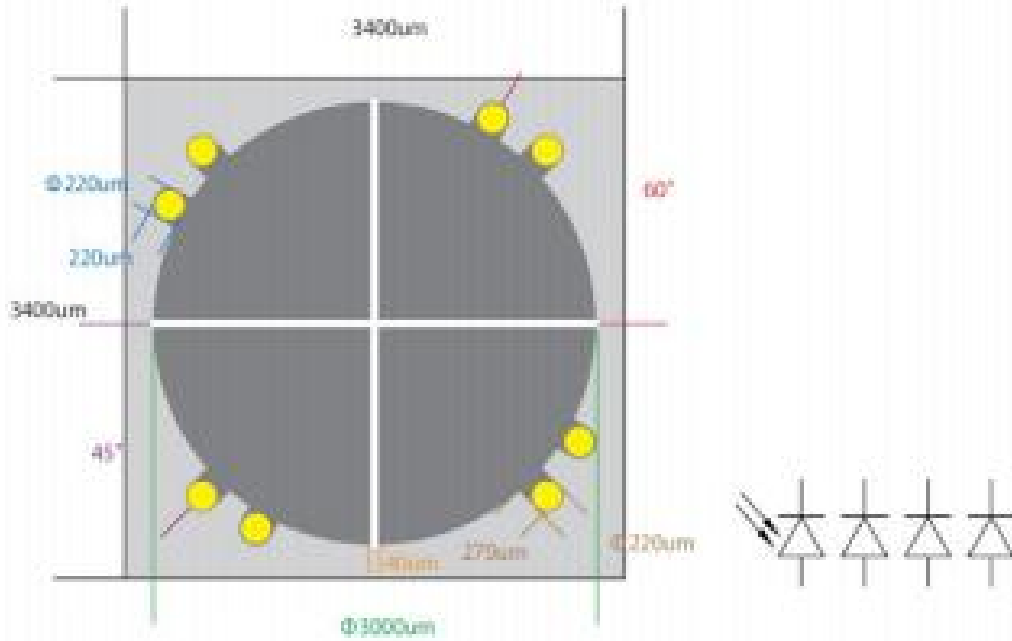

## Remarks:

The model is a pin indium gallium arsenide quadrant photodiode with a 3.0mm diameter active area.

The top anode and cathode metals are gold, suitable for gold wire and aluminum wire bonding.

There is no back metal.

