

320-1100nm Silicon-based Bias Photodetector, Active area $\Phi 10.0\text{mm}$



- **Product Description**

IdealPhotonics' silicon-based bias photodetector has a light sensitivity range covering 200nm to 1100nm. It features extremely low noise, fast response, no gain, and low cost. It is suitable for conventional optoelectronic detection applications, offering excellent performance and high cost-effectiveness. Comprehensive orientation technical support is provided, and it is commonly used for ultraviolet and visible light measurement.



- **Product features**

Sensitivity range 200nm-1100nm, commonly used for ultraviolet and visible light measurement、 Bias-type detector with extremely low noise, fast response, and no gain 、 Low cost, suitable for conventional optoelectronic detection applications 、 Excellent performance, high cost-effectiveness, and full technical support 、 Provide customization services

- **Part Number**

MP-PD-M-S-10-BC3D100

- **Application area**

Ultraviolet and visible light measurement

- **Core parameters**

Wavelength	Active Area	Bandwidth
320-1100nm	Φ10mm	10MHz

● Dimension Drawing

Dimension

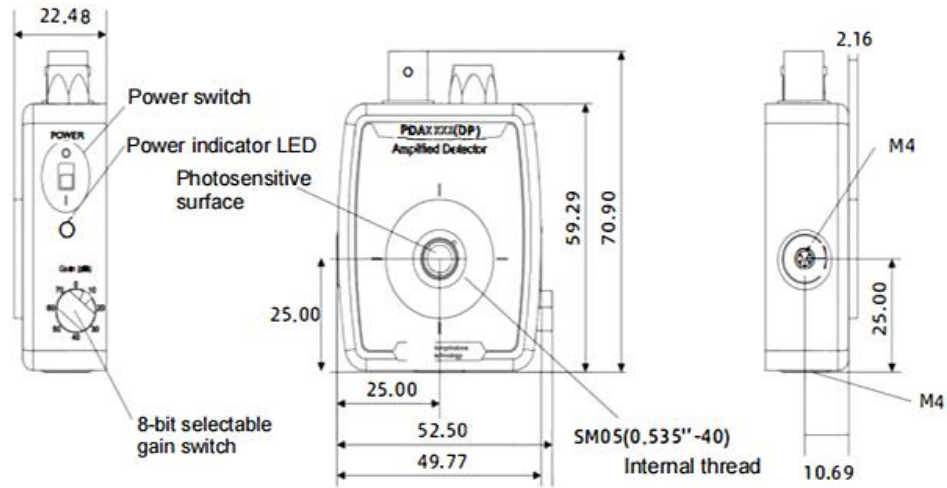

● General Parameters

Main Parameters

Parameter	Value		
Wavelength Range	200-1100nm	350-1100nm	320-1100nm
Active area	Φ1.0mm	Φ3.6mm	Φ10.0mm
Bandwidth Range	350MHz	25MHz	10MHz
Rise Time (@50Ω)	1ns	14ns	35ns



NEP	$5.0 \times 10^{-14} \text{W/Hz}^{1/2}$	$1.6 \times 10^{-14} \text{W/Hz}^{1/2}$	$2.4 \times 10^{-14} \text{W/Hz}^{1/2}$
Dark Current	0.3nA(Typ.)/10 nA(Max)	0.35nA(Typ.)/6.0nA(Max)	0.9nA(Typ.)/10nA(Max)
Junction Capacitance	6pF(Typ.)	40pF(Typ.)	150pF(Typ.)
Bias Voltage	10V		
Output Current	0~10mA		
Output Voltage	~9V(Hi-Z); ~170 mV(50Ω)		
Photosensitive Surface Depth	0.09" (2.2 mm)	0.09" (2.2 mm)	0.13" (3.3mm)
Operating Temperature	10-40°C		
Storage Temperature	-20-70°C		
Detector Net Weight	0.10kg		



Undervoltage Indicator	$V_{out} \leq 9V(Hi-Z)$ $V_{out} \leq 170mV(50\Omega)$				
Dimensions	2.79" X 1.96" X 0.89" (70.9 mm X 49.8 mm X 22.5 mm)				
Power Supply Battery	Power Switch	Signal Interface	Battery Monitoring	Mounting Interface	Optical Interface
A23 , 12VDC , 40mAh	Slide switch	BNC Female	Instant button	M4 X 2	SM1 X 1 SM0.5 X 1

SI Response Curve:

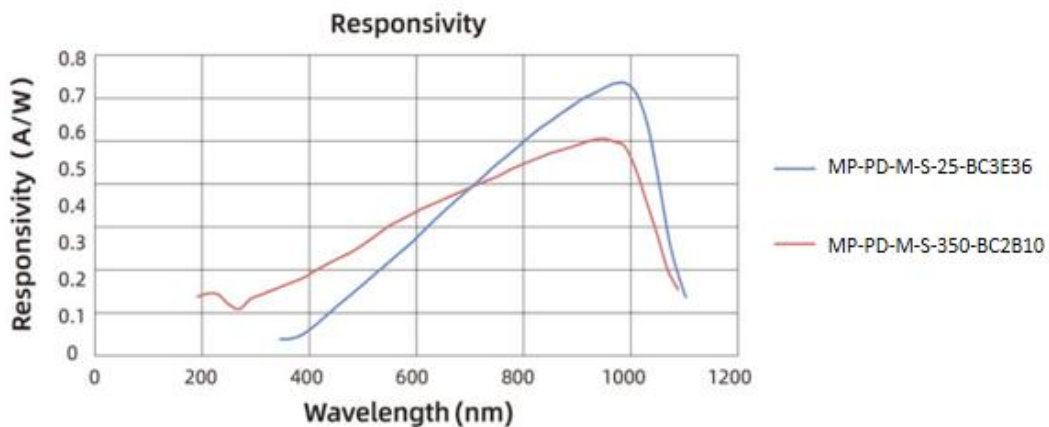



Attachment 1: Optional Configuration Table

Silicon-based Bias Photodetector					
Optional Configuration					
Product Name	Material	Type	Features	Wavelength Range Sensitivity Area	Optional Configurations
Photodetector	Si Silicon-based	Bias type	Conventional type	2B10 : 200-1100nm , Φ 1.0mm	
				3E36 : 350-1100nm , Φ 3.6mm	
				3D100 : 320-1100nm , Φ 10.0m m	



Attachment 2: Model Cross-Reference Table

Model	Specs
MP-PD-M-S-BC2B10	200-1100nm Silicon-based Bias Photodetector, Active area Φ 1.0mm, Rise Time 1ns, Bandwidth 350 MHz
MP-PD-M-S-BC3E36	350-1100nm Silicon-based Bias Photodetector, Active area Φ 3.6mm, Rise Time 14ns, Bandwidth 25 MHz
MP-PD-M-S-10-BC3D100	320-1100nm Silicon-based Bias Photodetector, Active area Φ 10.0mm, Rise Time 35ns, Bandwidth 10 MHz