



## 518nm Fiber Optic Variable Attenuator



- **Product Description**

Our optical fiber variable attenuator has the characteristics of fast adjustment of optical attenuation, small size, low insertion loss, low polarization-related loss, high mode-related stability and high reliability. It is mainly used in transmission networks, power balancing, product testing, related instruments and equipment, etc.

- **Product features**

Wide operating wavelength range and wide temperature range 、 Low insertion loss 、 Low polarization-dependent loss 、 High reliability and stability

## ● Part Number

MP-VOA-518-1-9-SA

## ● Application area

Product testing、 Single-mode transmission network、 Power balancing、

Receiver protection、 Related instruments and equipment

## ● Core parameters

Center Wavelength	Bandwidth
518nm	±10nm

## ● Dimension Drawing

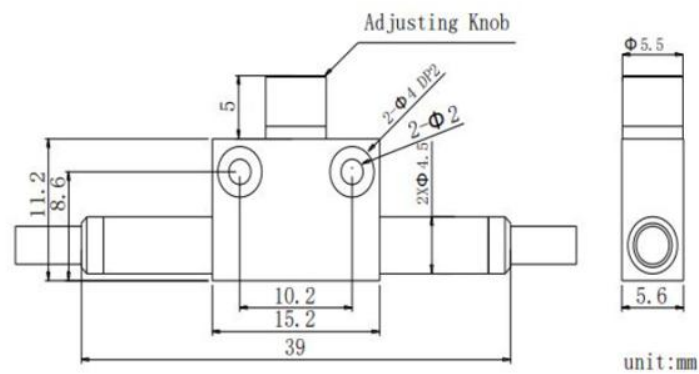

Fig.2 Package for 2mm cable or 3mm cable.  
The Color of Tube is Orange.

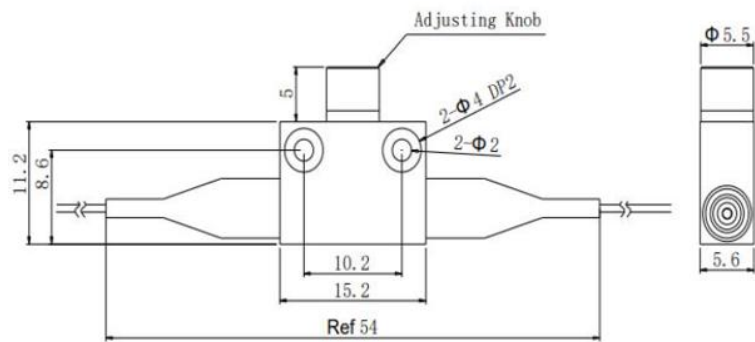

Fig.1 Package for bare fiber or 900um loose tube.  
The Color of Tube is Red.



## ● General Parameters

### Parameters

Parameter	Indication
Central wavelength	488nm or 518nm
Operating bandwidth	±10nm
Maximum additional loss	2.0dB
Minimum attenuation range	30dB
Resolution within 10dB attenuation range	0.1dB
Maximum PDL@23°C, at minimum	0.15dB
Maximum TDL (minimum attenuation)	0.7dB
Minimum return loss	50dB
Fiber type	Nufern 460-HP Fiber
Maximum tensile load	5N
Maximum optical power (CW)	100mw
Operating temperature	-5 to 70°C
Storage temperature	-40 to 85°C (Non-condensing)

### Note:

\*All parameters are measured without connectors

\*If connectors are added, IL will increase by 1.5dB and RL will decrease by 5dB.