

## 30m long optical path gas absorption cell (Aperture type)

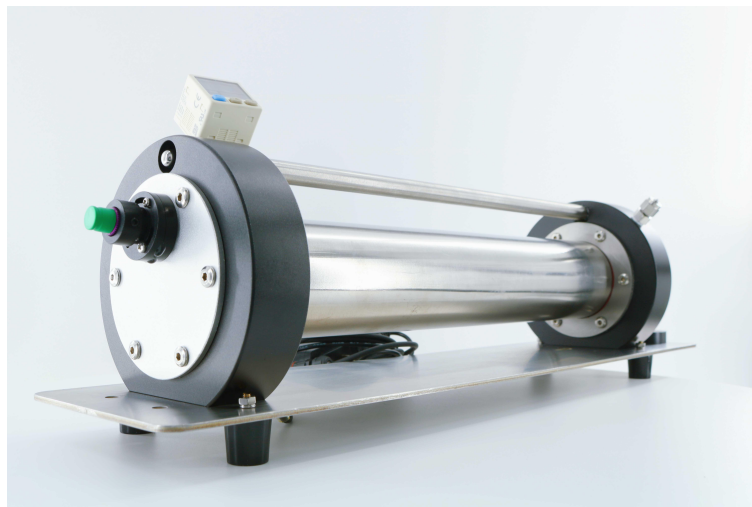

### ● Product Description

According to the tunable semiconductor laser absorption spectroscopy technology (TDLAS), a Herriott cell concave reflector is used to build a multi-reverse cavity long optical path gas cell. The reflective lens is plated with high-quality gold, silver and protective layer coating, which has high reflectivity. The compact design provides a relatively long absorption light path. The high-precision optical cavity gas cell is made of high-quality corrosion-resistant materials as a whole. It is suitable for industrial product application development, high-sensitivity gas analysis, major universities,



scientific research, online environmental monitoring, etc. The standard light source collimator can be directly installed, and the interface is M11X0.5 thread. There is no need to add an external reflector or adapter adjustment to align the light, which is very convenient to use.

## ● Product features

It adopts concave emission focusing optical path design, mirror anti-reflection film, protective film, and shockproof mounting base. It has stable optical path, direct access to collimated light source, and is easy to use. It is equipped with gas pool temperature and pressure display function, which is convenient for controlling gas pool temperature and pressure and safe operation. It is made of stainless steel, high-quality aluminum alloy oxidation treatment, and quartz glass. It is equipped with O-rings, which has good sealing and real-time observation; it is equipped with standard gas joints, which is convenient for use in various occasions.

## ● Part Number

MP-OGC-03-10-30-SS

## ● Application area

Monitoring tasks in industrial environments 、 Infrared absorption spectroscopy in scientific research 、 Industrial online monitoring

## ● Core parameters

Working Wavelength	Effective Optical Path
300nm-10um	30m

## ● Dimension Drawing

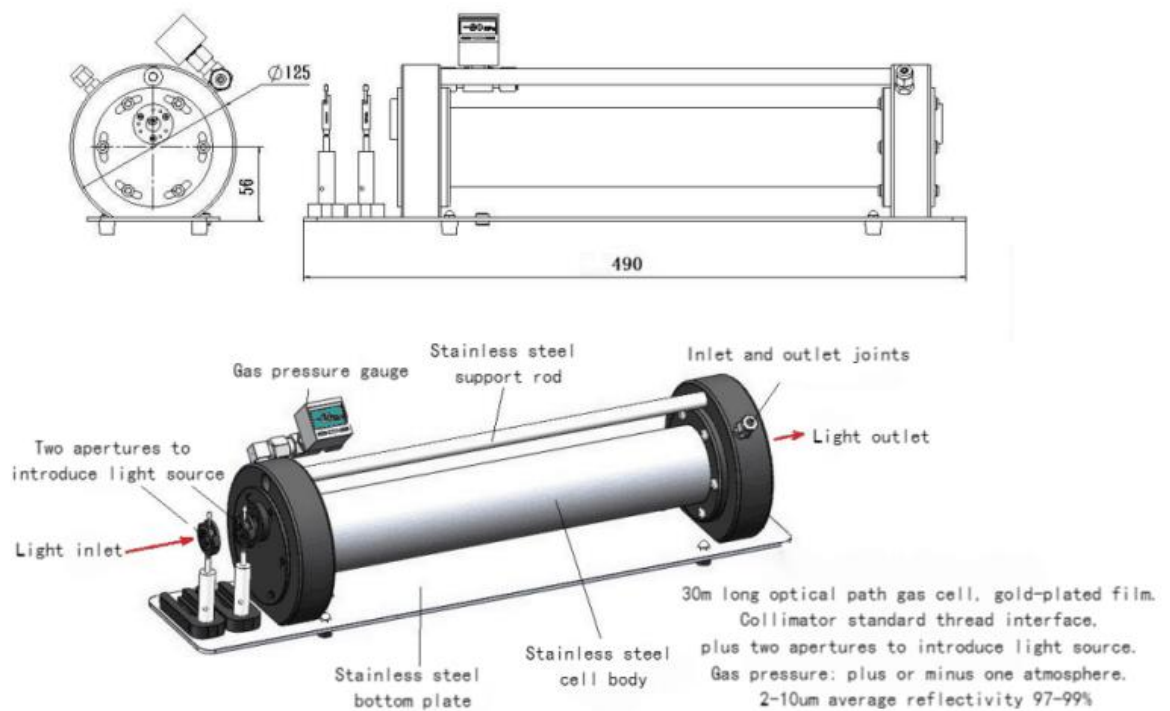

## ● General Parameters

### Parameter

Effective optical path	30 meters
Beam diameter	≤2.5mm
Mirror coating	Gold plating and protective film
Wavelength range	300nm~10um



Gas cell volume	1L (one standard atmospheric pressure)
Working gas pressure	-100KPa~100KPa
Window material	CaF2
Gas connector	φ6 quick connector
Dimensions	0.5x0.15x0.16(M)

**Note:** The gas cell needs to be placed on a stable workbench, the power fiber at the front end is connected to the FC/APC interface, the incident power is turned on, the light beam is emitted multiple times between the reflectors in the cell, and is emitted from the light exit hole at the rear end.

## **Warning:**

1. Do not disassemble the gas seal and the fixed parts for the light in and out.
2. Do not look directly into the light exit hole!