

## 3m long optical path gas absorption cell

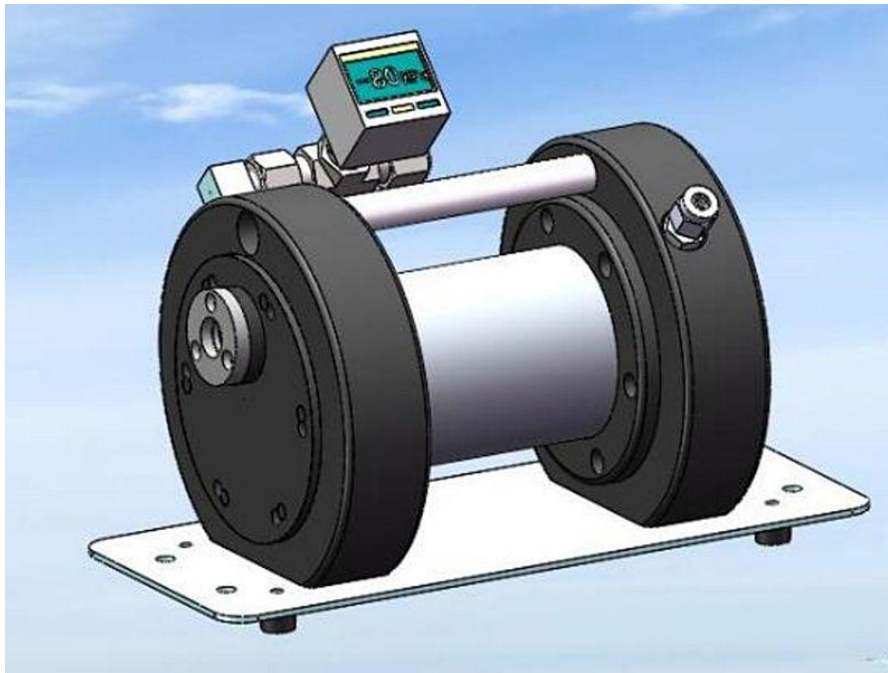

- **Product Description**

According to the tunable semiconductor laser absorption spectroscopy technology (TDLAS), a Herriott cell concave reflector is used to build a multi-reverse cavity long optical path gas cell. The reflective lens is plated with high-quality gold, silver and protective layer coating, which has high reflectivity. The compact design provides a relatively long absorption light path. The high-precision optical cavity gas cell is made of high-quality corrosion-resistant materials as a whole. It is suitable for industrial product application development, high-sensitivity gas analysis, major universities,

scientific research, online environmental monitoring, etc. The standard light source collimator can be directly installed, and the interface is M11X0.5 thread. There is no need to add an external reflector or adapter adjustment to align the light, which is very convenient to use.

## ● Product features

The air chamber structure is ultra-stable and has strong vibration resistance、 Small size, compact structure, easy to carry 、 15-meter long effective optical path、 Input and output are coupled with standard single-mode optical fiber

## ● Part Number

MP-OGC-075-3-3-SS

## ● Application area

Monitoring tasks in industrial environments 、 Infrared absorption spectroscopy in scientific research、 Industrial online monitoring

## ● Core parameters

Effective optical path	Wavelength range
3meters	750~3000nm

## ● General Parameters

### Parameter

Effective optical path	3 meters
Beam diameter	≤15mm
Mirror coating	Gold/silver plating and protective film
Wavelength range	750~3000um
Gas cell volume	0.3L (one standard atmospheric pressure)
Working gas pressure	-100KPa~100KPa
Window material	CaF <sub>2</sub>
Gas connector	φ6 quick connector
Dimensions	0.23X0.10X0.12(M)

## Product access operation

1. Connect the 12V DC power supply of the gas pressure gauge.
2. Connect the collimator standard interface M11X0.5 thread.

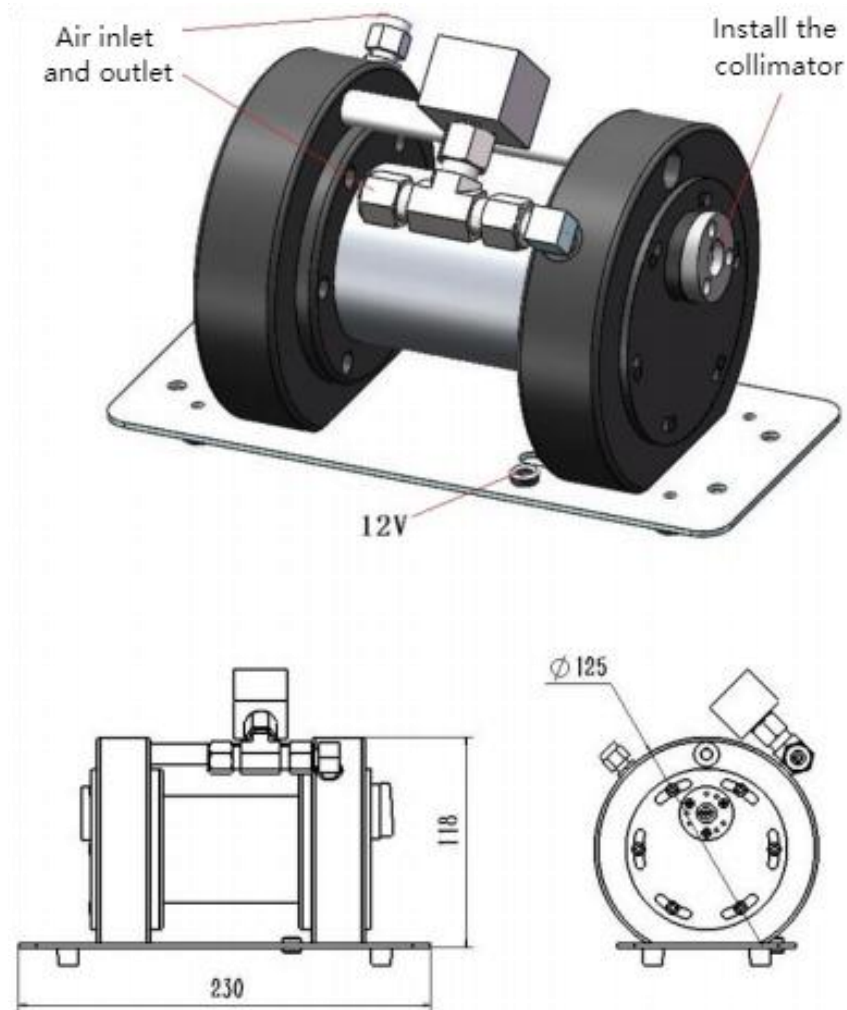

**Notice:**

- 1. The gas entering the gas pool must be filtered gas, and the gas after detection must be evacuated to ensure that the pool is clean.**
- 2. Do not disassemble the gas seal and the fixed parts of the light in and out.**
- 3. Do not look directly into the light outlet.**