

Single frequency narrow linewidth laser diode module single mode (633nm 30mw SM600)



● Product Description

LDRVMINI is a current drive and temperature control module for butterfly semiconductor lasers. Its main functions include: controlling the internal temperature of the laser, generating a constant current signal to drive the laser, and converting the external input voltage signal into a current drive. The module has two maximum current drive ranges, suitable for lasers of different power sizes (selected by circuit board jumpers).



● Product features

Small size、 Remote communication、 Customizable (630-1600nm any band)

● Part Number

MP-MINL-633-30-1M-SA-M

● Application area

Test spectrum、 Pump laser、 Laser communication

● Core parameters

Wavelength	Output Power	Linewidth
633nm	30mW	<100kHz

● General Parameters

Technical Parameters

Characteristics	Min.	Max.	Unit	Notes
Power Supply Voltage	4.8	5.5	VDC	DC
Power	5	10	W	
Laser Drive Current	0	149/378/624	mA	Optional
Laser Drive Voltage	0	3.1	V	@380mA



Response Frequency	0	10	MHz	-3db
Temperature Control Range	0	50	oC	
TEC Output Current	-1.5	1.5	A	
TEC Output Voltage	-4.4	+4.4	V	
Analog Input	-2.5	2.5	V	

Optional Wavelengths

Wavelength (nm)	Power (mW)	Linewidth	Wavelength (nm)	Power (mW)	Linewidth
633	30	<1KHz	1050	40	<1KHz
660	30	<1KHz	1064	40	<1KHz
770	10	<1KHz	1550	5	<1KHz
785	10	<1KHz	1550	100	<1KHz
830	20	<1KHz	1572	30	<1KHz



Typical spectral diagram

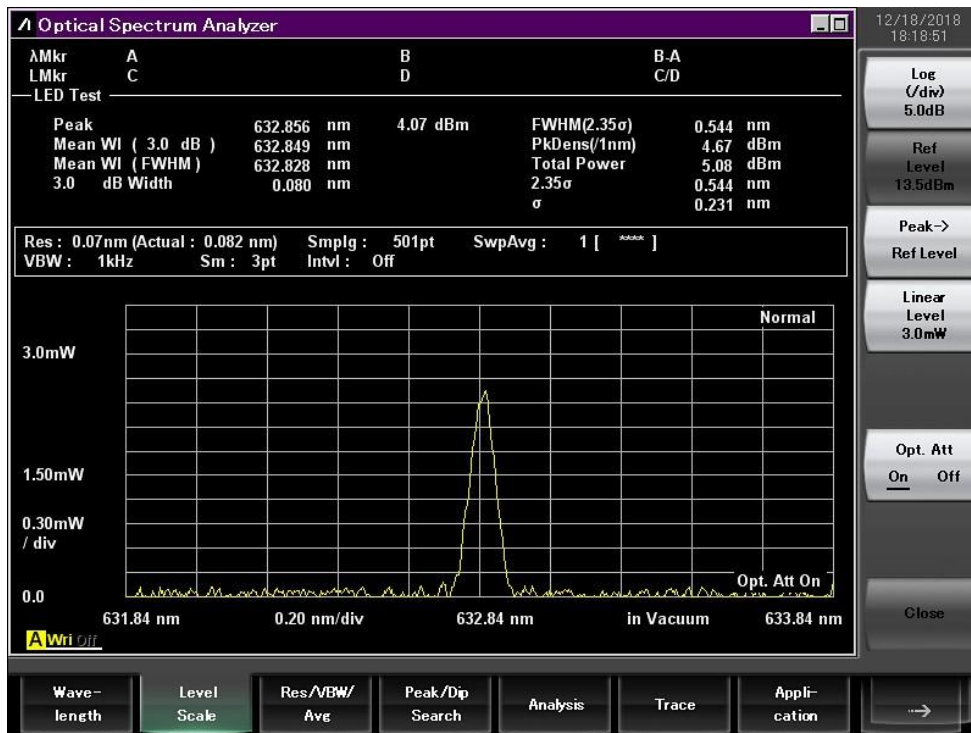

633nm narrow linewidth

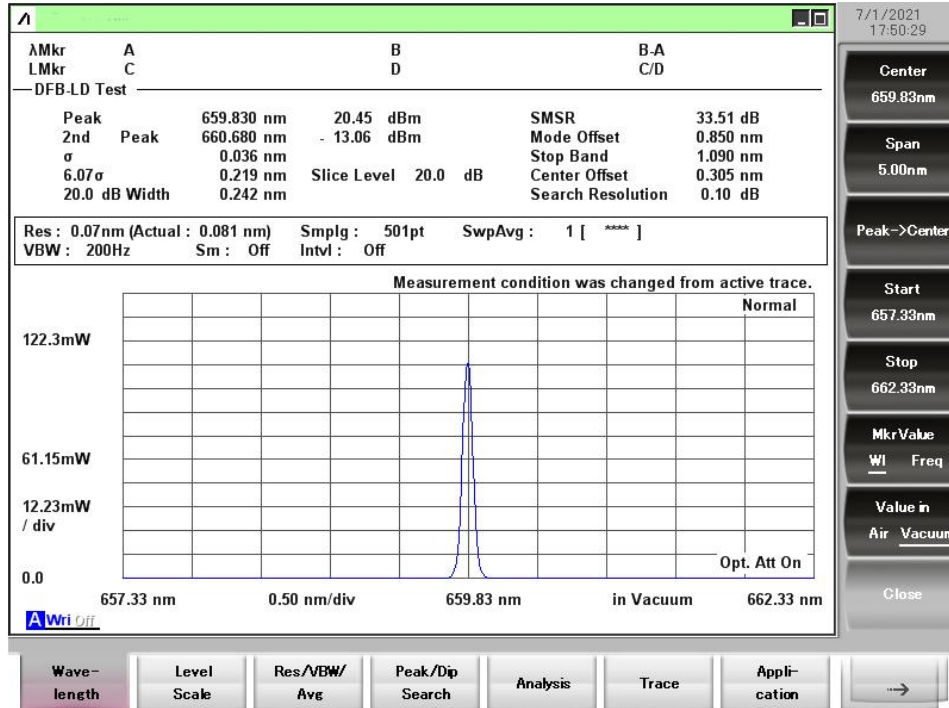

660nm narrow linewidth

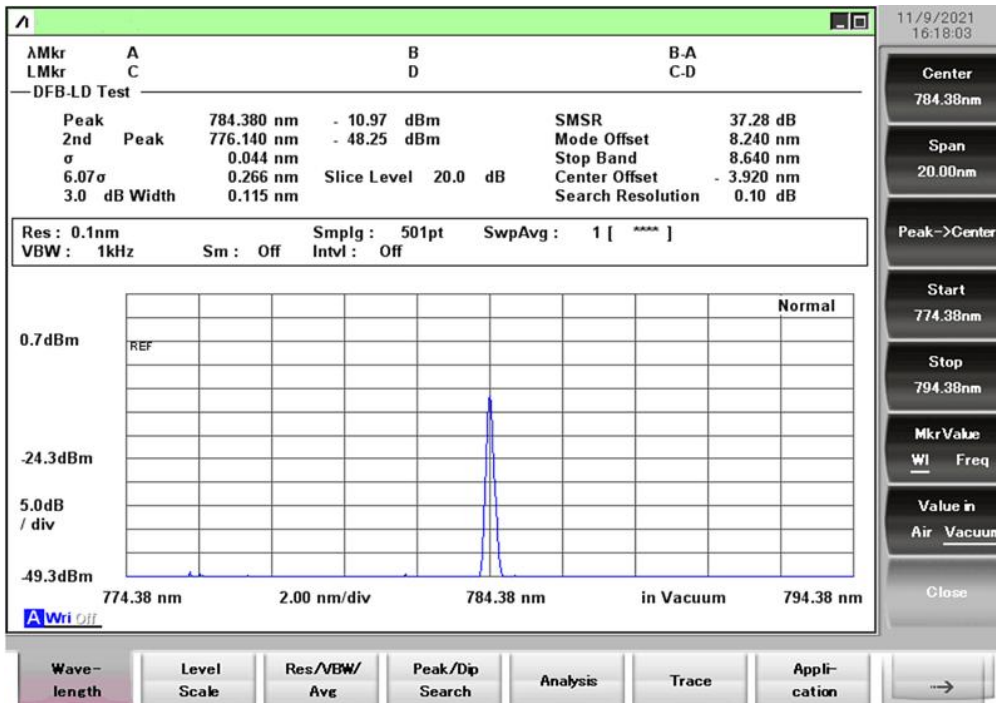

785nm narrow linewidth spectrum

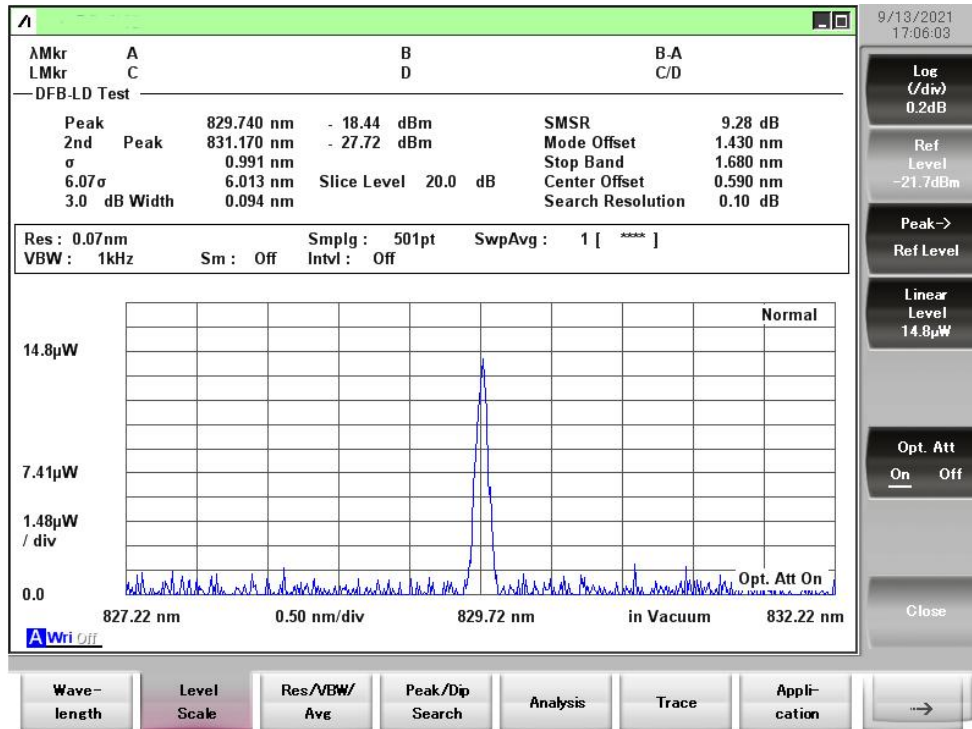

830nm narrow linewidth spectrum

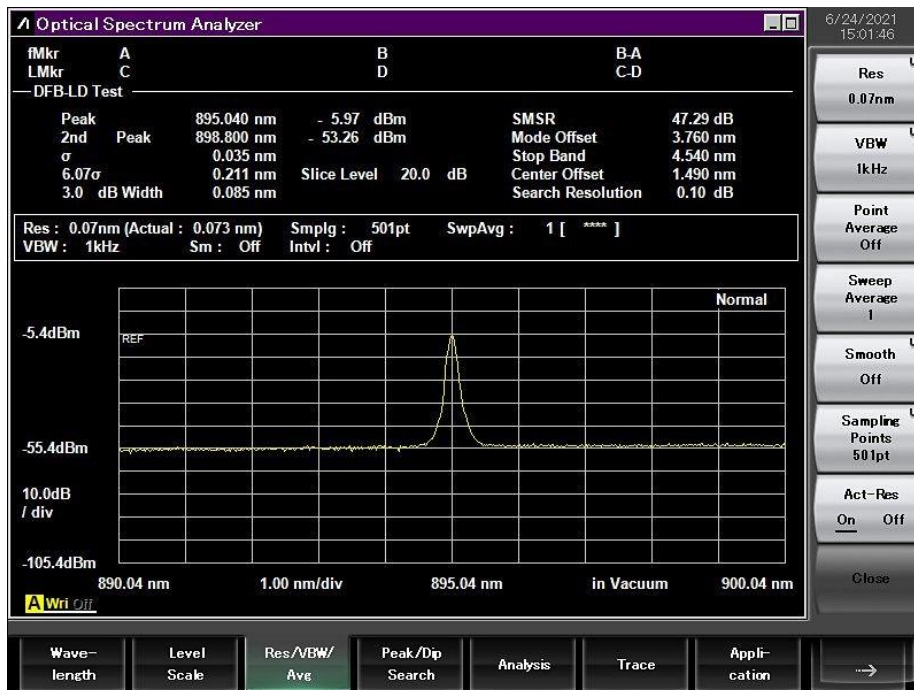

895nm narrow linewidth laser spectrum

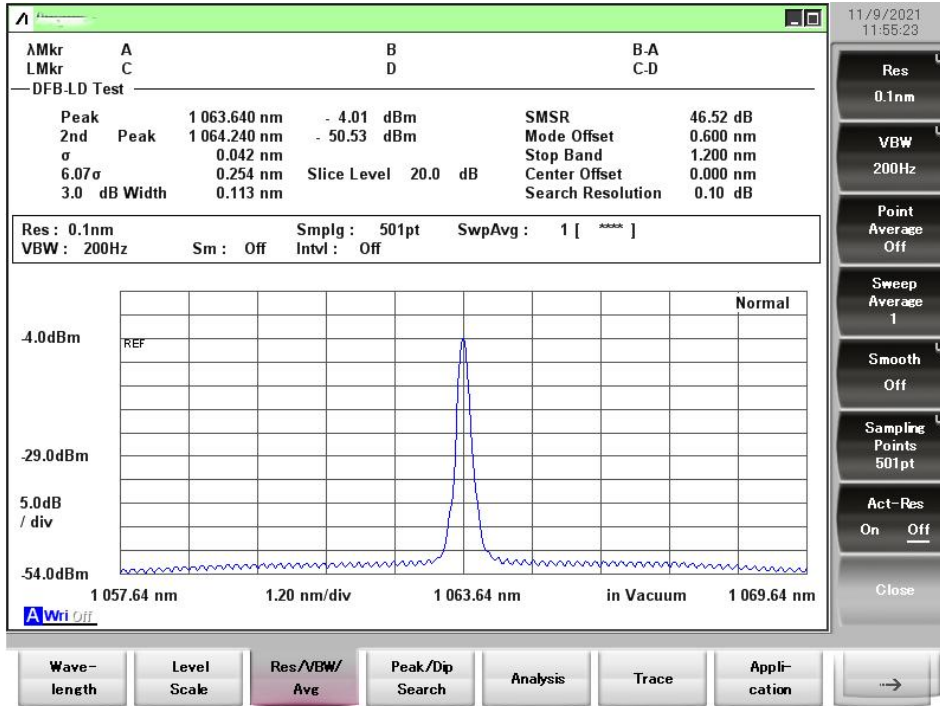

1064nm narrow linewidth spectrum

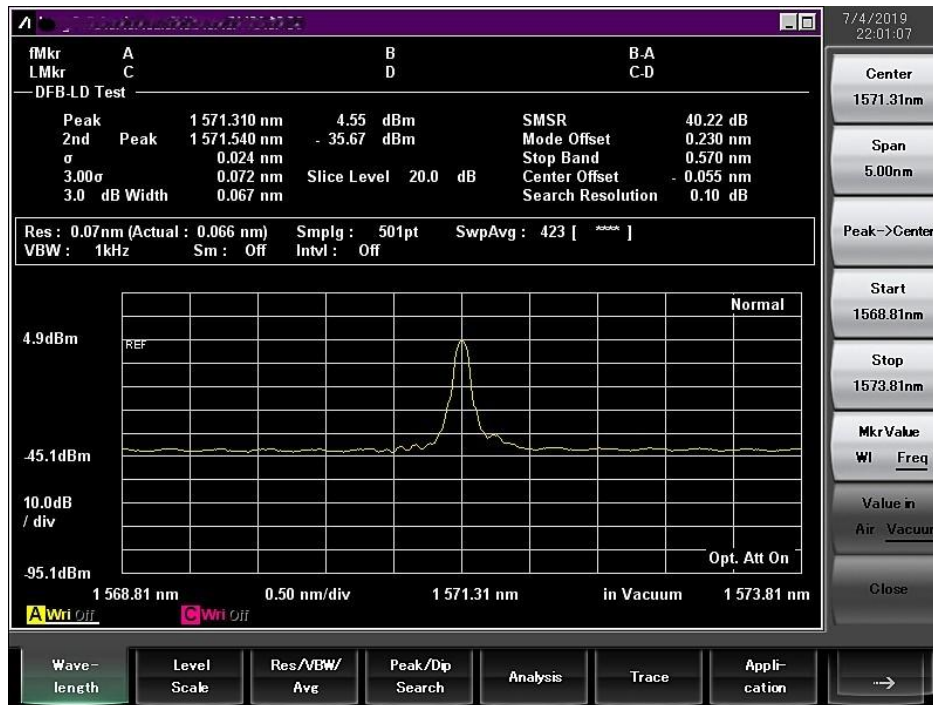

1572nm narrow linewidth spectrum

Power stability test

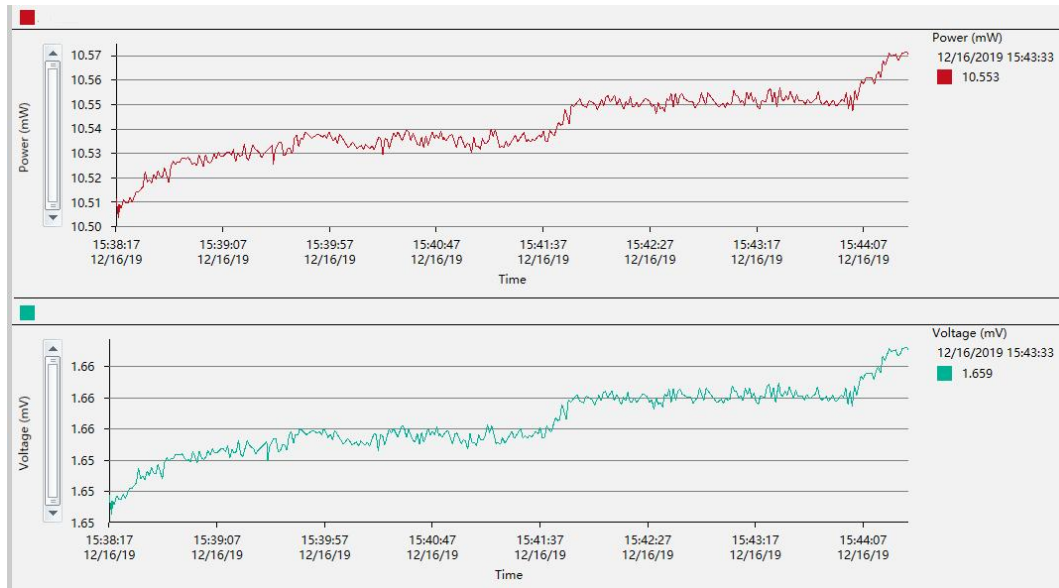

Spot analysis

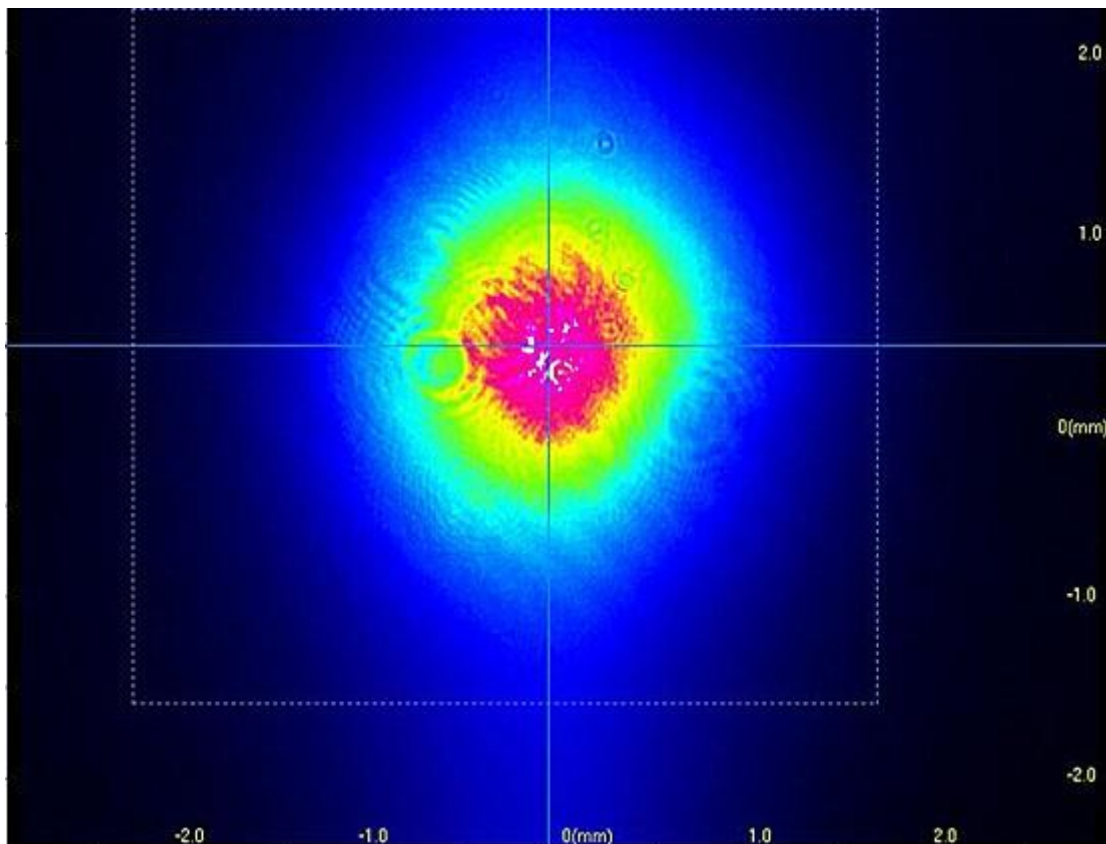

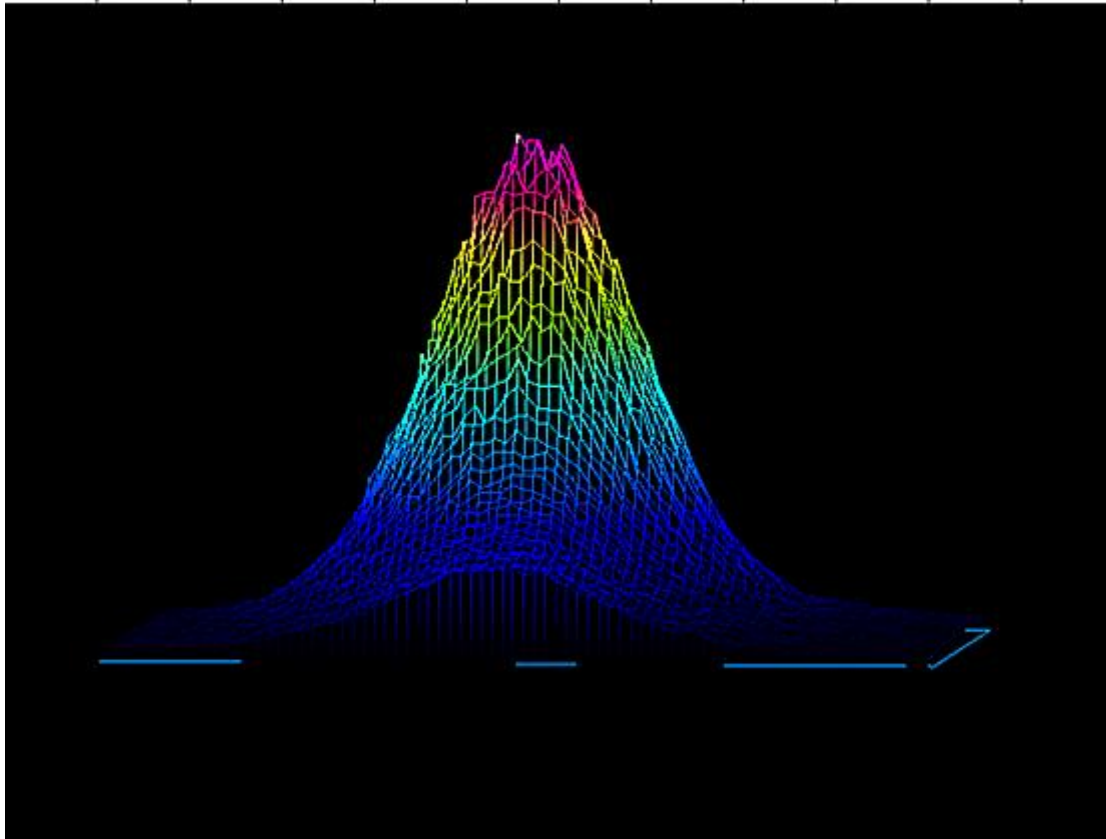

Ordering info

MP-NL-□□□□-☆-A8▽-XX

□□□□: Wavelength

☆: Output power

▽: Wavelength tolerance range

XX: Fiber and connector type

SA=SMF-28E+FC/APC

SP=SMF-28E+FC/PC

PP=PM Fiber+FC/PC

PA=PM Fiber+FC/APC

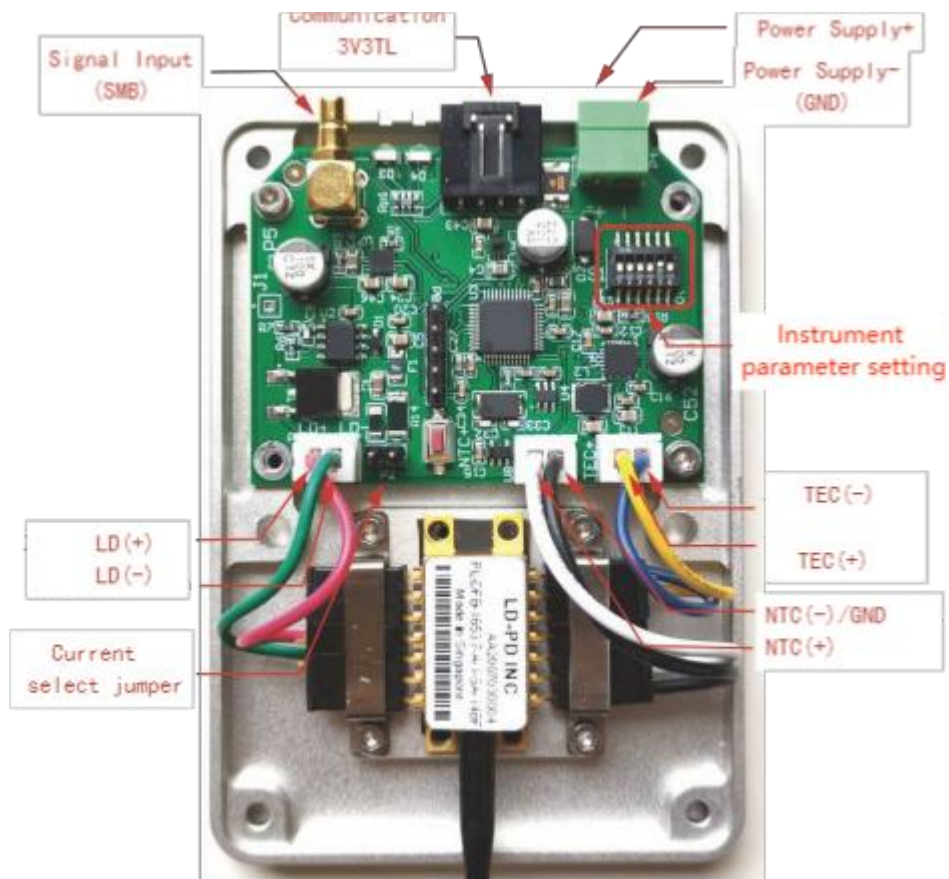

Important Note

Before powering on, please refer to the laser manual, the corresponding connector pinout, and the wiring on the circuit board to ensure compatibility between the laser and the current pinout. Incorrect pinout connections may damage the laser!

The negative input of the module's power supply, the bottom plate, and the NTC negative are all connected to ground. Additionally, the positive and negative outputs of the drive are not grounded. If any of the laser's functional pins are grounded (connected to its casing), extra attention is required.

If the laser's functional pins are grounded (e.g., positive of the laser is grounded), a layer of sticky thermal conductive silicone should be placed between the laser and the bottom case.

Do not use metal screws to fix the laser to ensure insulation between the laser casing and the

bottom case. If unsure, please consult the engineer from the seller! Incorrect grounding will cause abnormal module behavior or even burn out the laser.

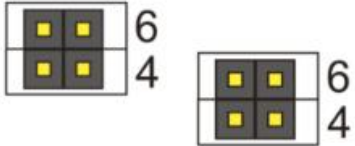
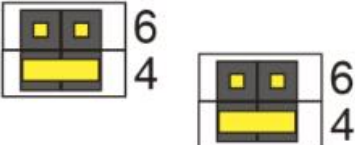
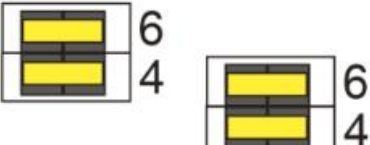
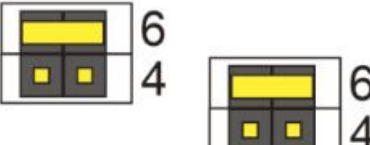
Current selection patch cord status	PN# / Max. drive current
	LDRVMLN150 149mA
	LDRVMLN380 378mA
	LDRVMLN600 624mA
	LDRVMLN400 394mA

The jumpers P3 and P10 must be consistent, otherwise the instrument will not work properly! All operations should be performed with the power off.

Voltage select patch cord		
Input voltage	5V	Max. Drive operating voltage
5V	Close	2.8 V
6V	Disconnect	3.7 V



If the laser has a built-in voltage divider resistor, try not to use it, as it will cause the external drive voltage to be insufficient and the laser will be in an undervoltage state.

The green light indicates that the temperature has stabilized. Use a jumper cap to short RX and GND to start the current source. Please use this function after the parameters are fully set.

From left to right:

Power Interface: 3.81mm connector, 5V 3A

Communication Interface: Serial communication, baud rate 115200bps, 8 data bits, 1 stop bit, no parity bit; 3.3V TTL level.

You can use a jumper to short the GND and RX pins, causing the system to begin driving the laser according to the preset internal current. Please make sure all parameters are properly set before using this function.

COM Light: Communication indicator light, which turns red when GND and RX are shorted.

SYS Light: System status light. It shows yellow when the laser is not installed or the laser temperature is not stable at the set value. It turns green when the laser temperature stabilizes.

It turns red when the internal driving current is turned on.

INPUT: SMB connector, input voltage 02.5V, input frequency 010MHz.

External Signal Input

The signal input terminal INPUT on the rear panel of the instrument is used to receive external input. When the internal bias signal is not enabled, the equivalent circuit is as shown below:

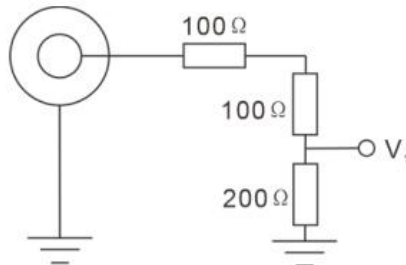

The driving current of the laser is:

$$I_{\text{Laser}} = (V_1/1.25V) \times I_{\text{max}}$$

$$I_{\text{max}} = 149\text{mA}, 378\text{mA etc}$$

When the internal signal is turned on, the equivalent circuit is as follows:

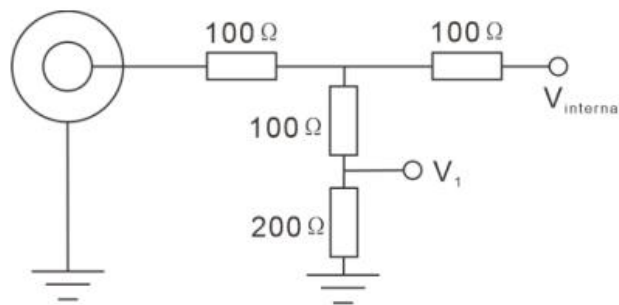

If only the internal signal is used, all connections on the INPUT terminal should be disconnected. If both internal and external signals are to be used simultaneously, please calculate the final effect based on the equivalent circuit shown above.



PC Control Interface

Reassemble the instrument cover, connect the controller to the power supply, and connect the computer via a USB cable. Press the power button (①) to turn on the instrument.

Windows 7 and above systems will automatically prompt for the USB driver installation. If using other systems or if automatic installation fails, please download the appropriate driver from <http://www.ftdichip.com/Drivers/VCP.htm>. Once the driver is installed, a virtual serial device will appear in the "Device Manager." Then, open the dedicated software on the computer, as shown below:

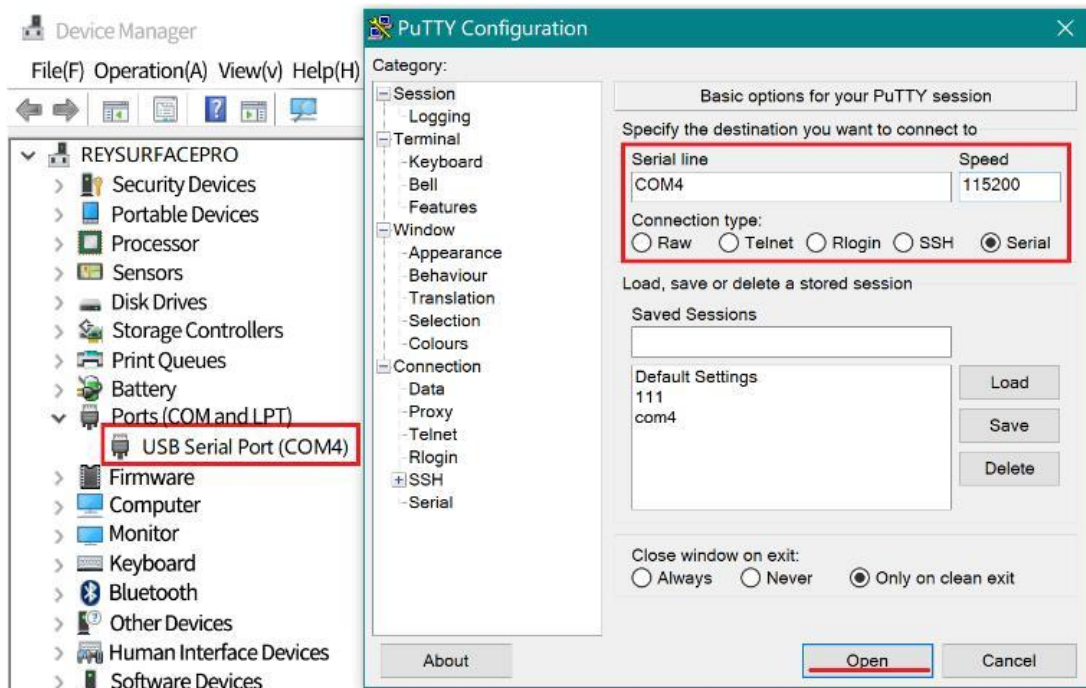

The computer is the main control end (host computer) and sends a string command. A line of command starts with a colon ":" and ends with a carriage return ($\backslash r \backslash n$). The lower computer returns information after execution. All the following functions can be accessed through the supporting software.



It is recommended to complete the settings with the supporting LDPD software and get the correct waveform, then click Save to save the parameters to the lower computer, and then transfer it to other clients for control.

The operation mode is as follows:

Operating mode	
1	<p>>>>>> Send auto on to start, return (1) Auto run started. [[OK]]\r\n</p> <p style="text-align: center;">>>>>> The laser loads the set current</p> <p>>>>>> Send auto off to stop, return (0) Auto run stopped. [[OK]]\r\n</p>

Installation Precautions:

send	Function and Return Values
about	Return the current parameters of the lower machine:
	>> First line (%f) TEC.\r\n
	>> (Floating point number, consistent with the issued parameter)
	>> Second line (%d, %d, %d) PGA, freq, amp.\r\n
	>> (For LDRV module, the above parameters are meaningless)
	>> Third line (%d, %d, %d) bias.\r\n
	>> ((Values consistent with the issued command bias a, b, c)
	>> Fourth line (%d, %d) dm, phase.\r\n
>> (For LDRV, these parameters are meaningless)	
version	Reply: RYMLASER



temp	Returns the current ambient temperature value and laser temperature.
tec x	Sets the target temperature for the laser, where x is the temperature in Celsius, which can be a decimal.
tecPkI	Sets the PID parameters for the temperature control system to ensure stability. The user can adjust the parameters to achieve faster or slower response.
kD	For professional users only! Incorrect PID parameters may cause temperature oscillation and even damage the laser. Factory default values: kP =1500; kI=4000; kD=10
tecfast	TEC standard mode, using the stored PID parameters.
tecslow	TEC slow mode, setting kP/2, kI/8, which will reduce the time constant of the temperature control system.
bias abc	• a: Current setting (0~65535)
	• b: Current limit setting (0~65535)
	• c: Meaningless parameter, set to 1 or higher.
	Values for a and b are calculated using the following formula:
	$a = (I_{set} / I_{max}) * 65536$
	where Iset is the desired current, and Imax is the maximum current of the instrument (refer to Instrument.ini for the model-specific value).
save	Save all current parameters, which will be automatically called



upon the next startup.

Insulation of Laser with Shell:

- 1. When the laser has a functional pin connected to the shell (such as NEL laser, usually the LD anode is connected to the shell), the laser shell must be insulated from the base: a layer of thermal conductive silicone pad is placed under the laser, and metal screws are not used to fix it.**
- 2. The laser current gear needs to be realized through a jumper cap, and then the system self-identification is enabled by dialing code 1. The mismatch between the two will cause the system's self-identification and the actual current to mismatch, which may cause the laser to burn out!**
- 3. It is recommended to connect an LED lamp bead or a cheap red laser to test whether the current setting is working properly.**
- 4. Temperature oscillation indicates that the temperature control PID parameter setting is incorrect (all temperature controllers have a PID parameter selection link, which can be adjusted by referring to various instructions on the Internet). The temperature control parameter adjustment commands are tecp, kp, kl, and kd. After sending, the effect will be immediately produced. Observe the temperature response accuracy and speed. After the adjustment is completed, use the save command to save.**



5. The module has no switch. After connecting the power supply, the TEC part starts working immediately, but the laser current source does not start. The green light indicates that the temperature has stabilized. Use a jumper cap to short RX and GND to make the current source start working. Please use this function after all parameters are set.