

1650nm 200mW PM FP Laser Diode

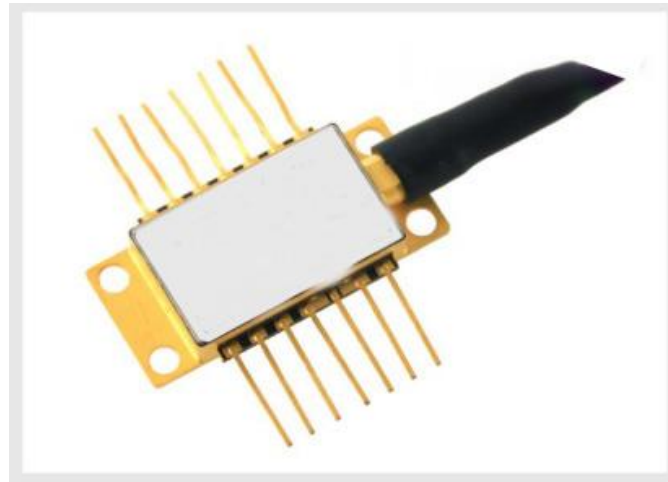

● Product Description

The 1650nm single-mode laser module adopts a 14-pin butterfly package. All chips are mounted on a 2.1mm COS (Chip on Submount) inside the package, and it comes standard with a built-in thermistor, TEC, and photodiode. Our 1625nm single-mode product line is widely used in applications such as optical data storage, printing, laser ranging, illumination, defense, spectral analysis, and graphics processing.

● Product features

Stable output;; Low noise; Wide operating temperature range



● **Part Number**

MP-FP-1650-200-14BF-PA

● **Application area**

Fiber optic communication systems | Optical sensing | Laser ranging |

Laboratory research | Industrial inspection equipment

● **Core parameters**

Central Wavelength	Spectral Width	Output Power
1630nm - 1670nm	1 nm - 6 nm	200mW

● **Dimension Drawing**

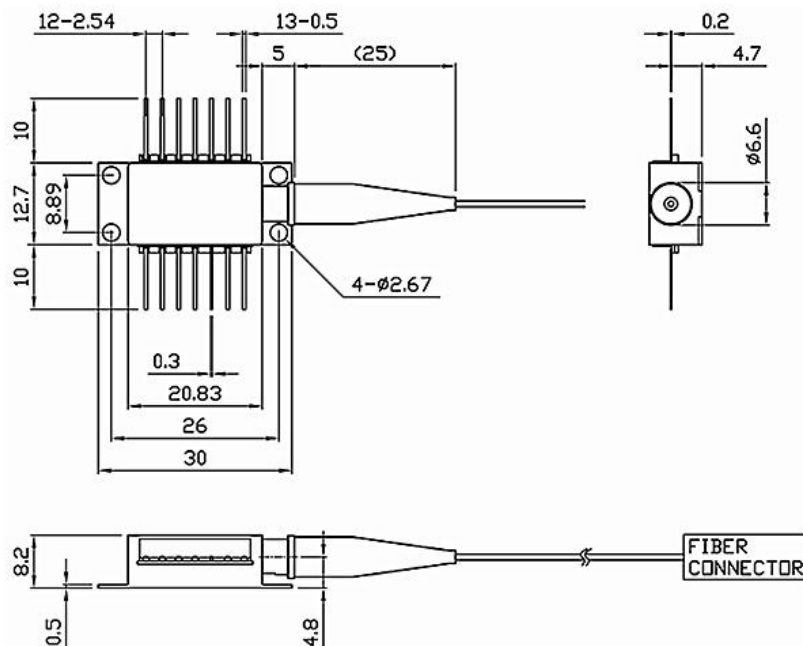



● General Parameters

Detailed Parameters

Specification Table

Electrical / Optical Characteristics (Tsub = 25 °C, CW bias, unless otherwise specified)

Parameter	Symbol	Min	Typ	Max	Unit
Central Wavelength	λ	1630	1650	1670	nm
Spectral Width	$\Delta\lambda$	1	3	6	nm
Threshold Current	I _{th}	—	80	100	mA
Operating Current	I _{op}	—	1000	1200	mA
Fiber Output Power	P _f	100	200	500	mW
PD Dark Current (VRD=5V)	I _d	—	—	0.1	μA
Polarization Extinction Ratio (PM version)	PER	17	20	—	dB
Coupled Fiber Type	SMF-28E/PM1550				
Forward Voltage	V _f	—	1.8	2.5	V
Thermistor Resistance	RT	9.5	10	10.5	kΩ

Thermistor Temperature Coefficient	—	—	-4.4	—	%/° C
Connector	FC/APC				

Pin Definition:

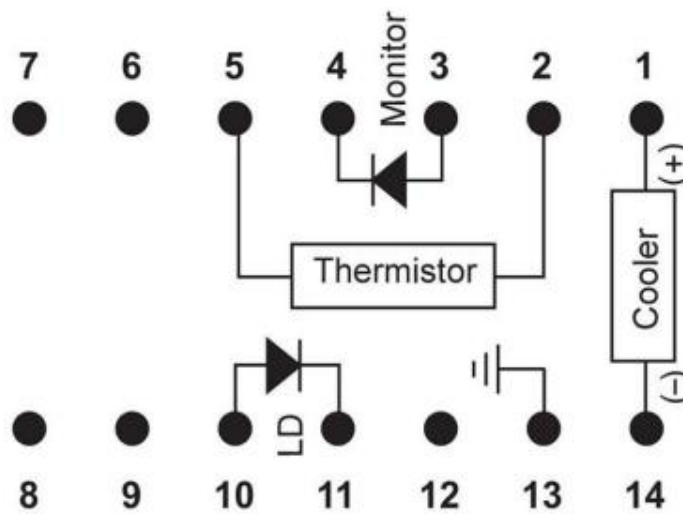

PIN#	Function	PIN#	Function
1	Thermoelectric Cooler (+)	8	N/C
2	Thermistor	9	N/C
3	PD Monitor Anode (-)	10	Laser Anode (+)
4	PD Monitor Cathode (+)	11	Laser Cathode (-)



5	Thermistor	12	N/C
6	N/C	13	Case Ground
7	N/C	14	Thermoelectric Cooler (-)

Absolute Maximum Ratings

Parameter	Unit	Min	Typ	Max
Case Temperature	°C	-5	25	70
Chip Temperature	°C	+10	25	40
Operating Current	mA	0	1200	1500
Forward Voltage	V	—	1.8	2.5
TEC Current	A	—	1.5	2.0
Reverse Voltage (LD)	V	—	—	1.8
Reverse Voltage (PD)	V	—	—	10

Characteristic Curves

Spectrum Diagram:

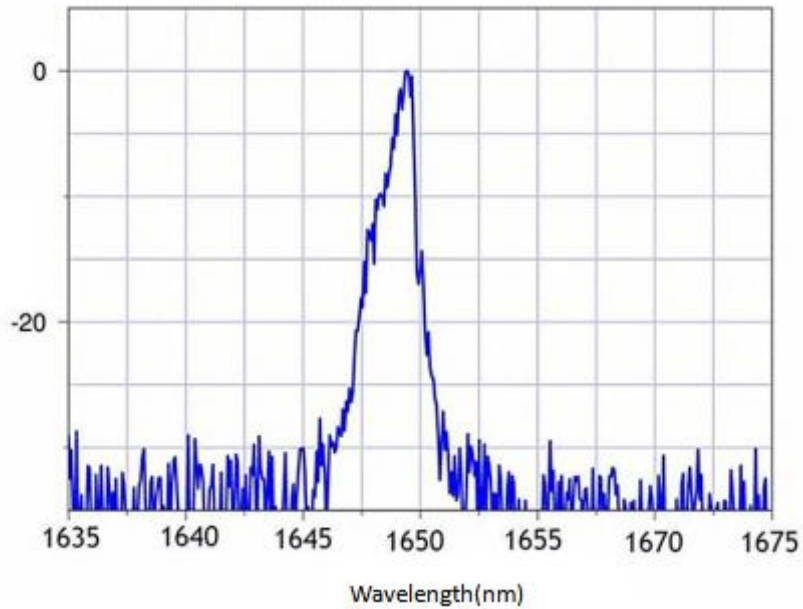

L-I Curve:

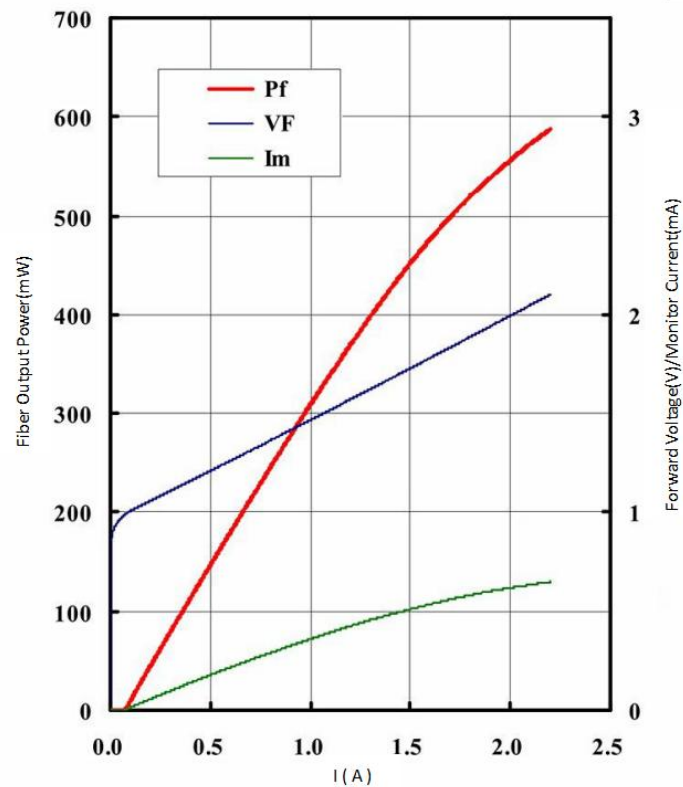



Ordering Information:

MP-FP-□□□□-☆-A8▽-XX

□□□□: Wavelength

405: 405 nm

633: 633 nm

680: 680 nm

850: 850 nm

1550: 1550 nm

1950: 1950 nm

☆: Output Power

A: 50 mW

B: 100 mW

▽: Wavelength Tolerance

1: ±5 nm

2: ±10 nm

XX: Fiber Type & Connector

SA = SMF-28E + FC/APC

SP = SMF-28E + FC/PC



PP = PM Fiber + FC/PC

PA = PM Fiber + FC/APC