

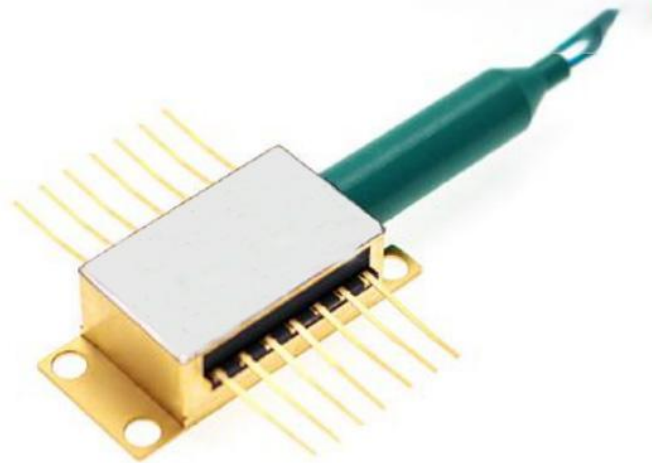

808nm 200mW SM Pumping Laser



- **Product Description**

Optical output power up to 250mW, 14-pin butterfly package, wavelength locked by fiber Bragg grating, integrated TEC, thermistor, and PD, excellent low power stability.

- **Product features**

Single-mode fiber output; high power stability; narrow linewidth characteristic; low noise design; industrial-grade package

- **Part Number**

MP-FP-808-200-14BF-SA



● Application area

Fiber Amplifier Pumping | Fiber Lasers | Coherent Optical Communication |

Fiber Optic Sensing | Quantum Technology

● Core parameters

Center Wavelength	Output Power
808nm	400mW

● Dimension Drawing

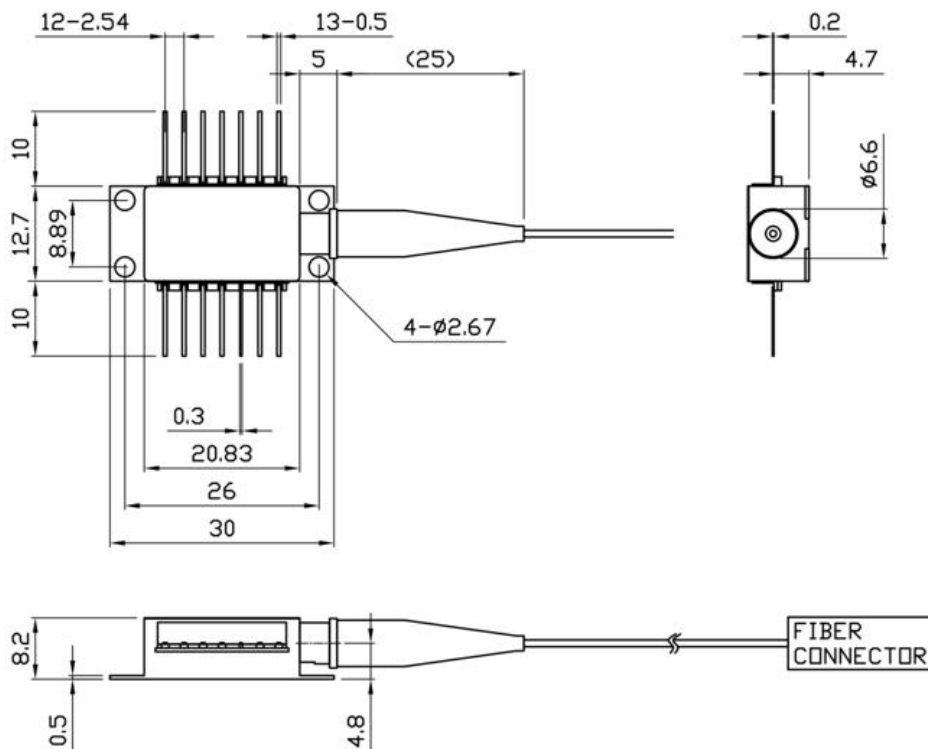



● General Parameters

Model Parameters

Parameter	Symbol	Min	Typ	Max	Unit
Center Wavelength	λ	807	808	809	nm
Spectral Width	$\Delta\lambda$	0.6	0.8	2.0	nm
Threshold Current	I_{th}	-	30	40	mA
Operating Current	I_{op}	-	250	350	mA
Fiber Output Power	P_f	100	200	250	mW
Wavelength Tuning vs. Temperature	$\Delta\lambda/T$	-	-	0.01	nm/°C
Tracking Ratio ($0.1P_{op} < P_f < P_{op}$) ¹	TR	0.52	-	1.48	-
Tracking Error ²	TE	-48	-	+48	-
PD Monitor Responsivity	IBF	0.5	-	5	$\mu\text{A}/\text{mW}$
PD Dark Current (VRD = 5 V)	I_d	-	-	0.1	μA
Extinction Ratio (PM Version)	PER	17	20	-	dB



Fiber Type	HI780				
Forward Voltage	Vf	-	1.8	2.6	V
Thermistor Resistance	RT	9.5	10	10.5	kΩ
Thermistor Temperature Coefficient	-	-	-4.4	-	%/°C
Output Connector	-	-	None or FC/APC	-	-

Note 1:

The tracking ratio is a measure of the tracking between the output power and the monitor photocurrent as the output power varies. On a plot of optical power versus back facet photocurrent, a straight line is drawn between the minimum power (30 mW) and the operating power (Pop). The tracking ratio is defined as the ratio of the measured optical power (as indicated by the data point on the graph) to the value derived from the straight line.

Note 2:

Tracking error is defined as the normalized change in output power relative to Pf at 25°C, i.e., $(P_f - P_{f-25}) / P_{f-25}$, over a case temperature range of 0°C to 75°C, at a constant back facet monitor current corresponding to the lowest back facet monitor current at $P_f = P_{op}$ at 0°C, 25°C, and 75°C.



Absolute maximum parameter:

Parameters	symbol	unit	Min.	typical	Max.	Test conditions
Body temperature	T_{OP}	°C	-5	25	70	
Chip temperature	T_{LD}	°C	+10	25	50	
Operating current	$I_f\text{-max}$	mA	0	250	350	
Forward voltage	V_R	V	0.8	1.2	1.8	
TEC current	I_{TEC}	A	-	1.2	2.0	
Tec voltage	V_{TEC}	V	-	-	-	
Axial tension		N	-	-	5N	3x10s
Lateral pull		N	-	-	2.5N	3x10s
Fiber bending radius			16m			-
Reverse voltage (LD).		V	-	-	1.8	C=100pF,R=1.5 KΩ, HBM
Reverse voltage (PD).	V_{PD}	V	-	-	10	C=100pF,R=1.5 KΩ, HBM
LD electrostatic discharge	V_{ESD-LD}	V		-	1000	



PD electrostatic discharge	V_{ESD-PD}	V	-	500	
PD forward current	I_{PF}	mA	-	10	
lead soldering time		S	-	10s	300°C
Storage temperature	T_{STG}	°C	-40	+85	2000hr

Characteristic curves

Spectrogram:

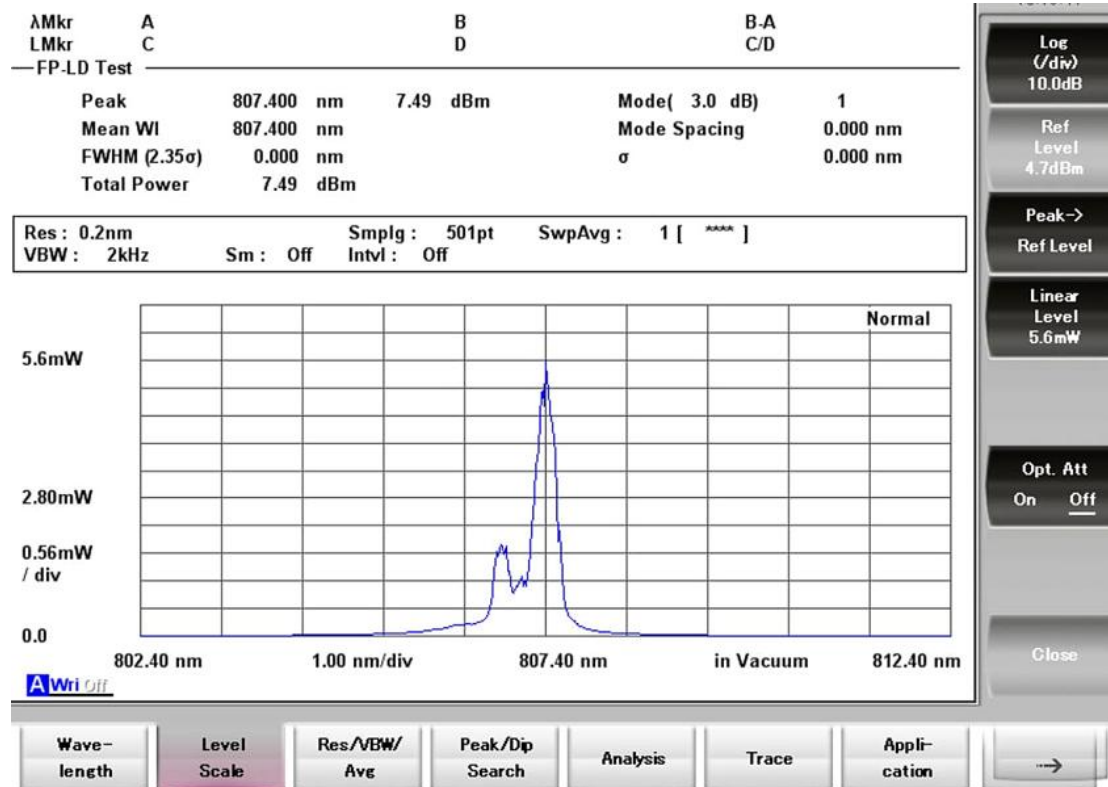

Output power curve

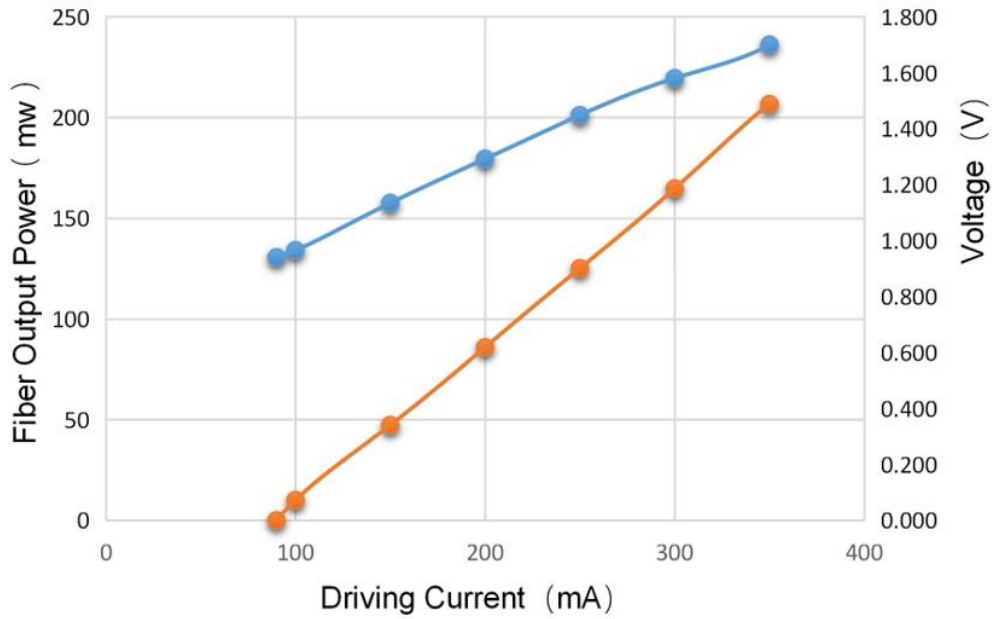

Pin definition

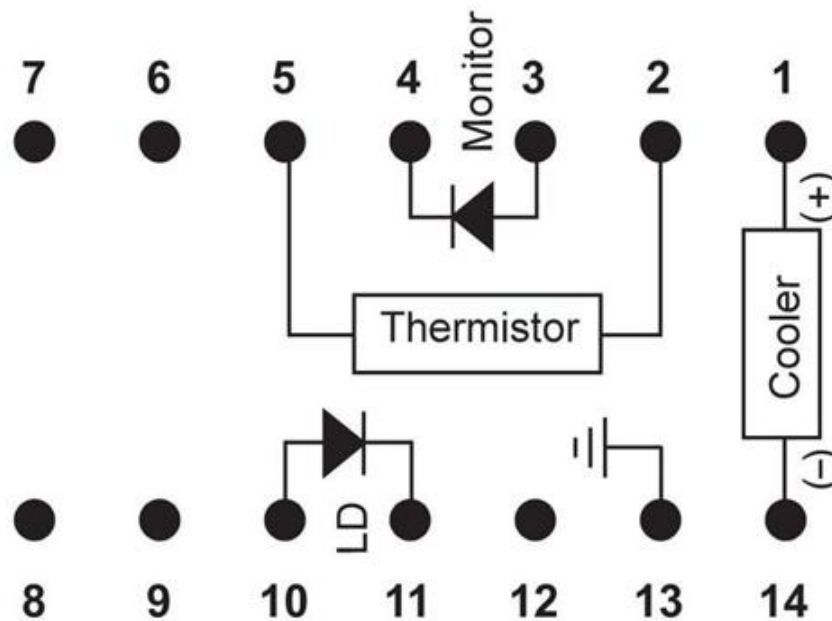

1	Thermoelectric Cooler (+)	8	N/C
2	Thermistor	9	N/C



3	PD Monitor Anode (-)	10	Laser Anode (+)
4	PD Monitor Cathode (+)	11	Laser Cathode (-)
5	Thermistor	12	N/C
6	N/C	13	Case Ground
7	N/C	14	Thermoelectric Cooler (-)

Ordering information

MP-FP-□□□□-☆-A8▽-XX

□□□□: Wavelength

405: 405nm

633: 633nm

680: 680nm

808: 808nm

850: 850nm

910: 910nm

980: 980nm

1550: 1550nm

☆ : Output Power

A: 100mW

B: 200mW



C: 250mW

▽: Wavelength Tolerance

1: $\pm 1\text{nm}$

2: $\pm 2\text{nm}$

XX: Fiber and Connector Type

SA=HI780+ FC/APC

SP=HI780+ FC/PC

PP=PM 980 + FC/PC

PA=PM980+ FC/APC