

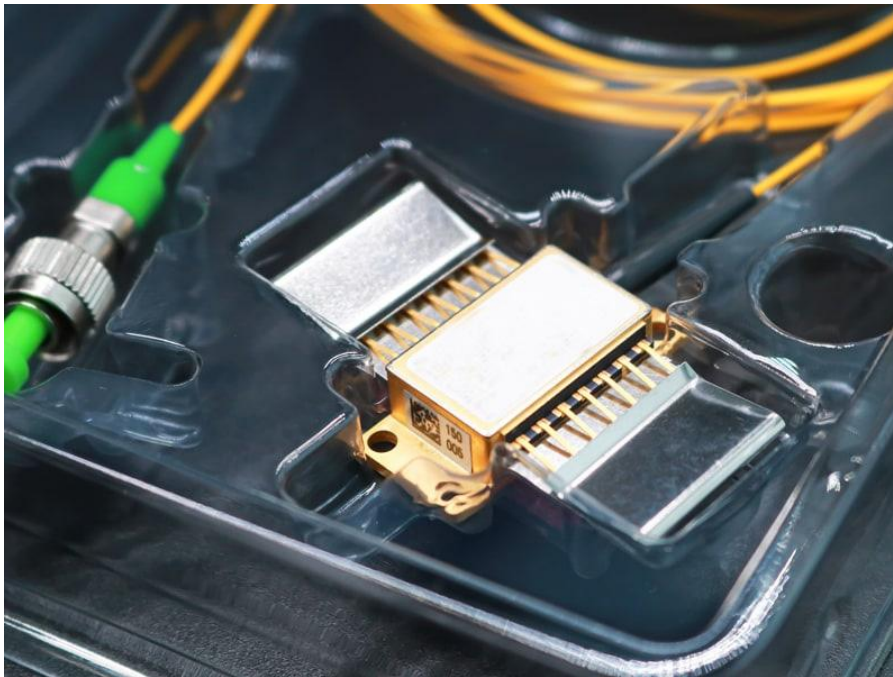

1690nm 10mW PM SLD Laser Diode



● Product Description

The 1690nm SLD is a broadband SLD operating in inherent superluminescent emission mode. Its superluminescent characteristic delivers broader spectral bandwidth under higher driving current, while conventional ASE-based SLEDs feature narrowed spectral bandwidth at elevated current. Its low coherence suppresses Rayleigh backscattering noise. Combined with high output power and wide spectral width, it counteracts optical receiver noise and improves spatial resolution for OCT and measurement sensitivity for sensing applications. This 1690 nm SLED

adopts a 14-pin butterfly package and complies with Bellcore GR-468-CORE specifications.

● Product features

Broad-spectrum output; polarization-maintaining fiber coupling; low coherence; high stability; intelligent control

● Part Number

MP-SLD-1690-10-A81-14BF-PA

● Application area

Optical Coherence Tomography | Fiber Optic Gyroscope | Fiber Sensing |
Device Testing | Biological Detection

● Core parameters

Center Wavelength	Output Power
1690 nm	10 mW

● Dimension Drawing

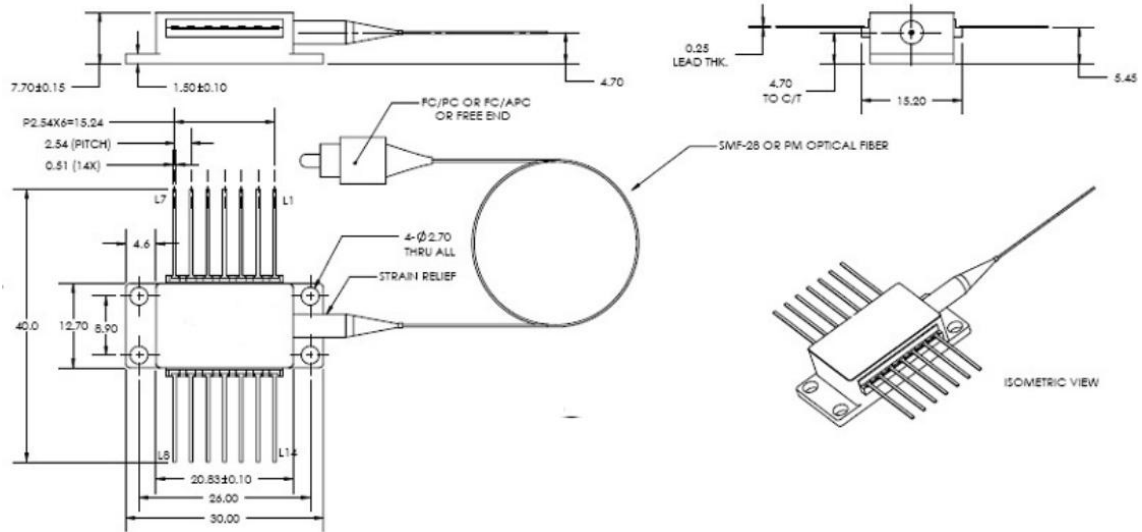

● General Parameters

Technical Specifications

(TSLED = 25 °C)

Parameter	Symbol	Condition	Min.	Typ.	Max.	Unit
Operating Current	I _{op}	—	—	—	400	mA
Forward Voltage	V _F	I _{op}	—	—	2	V
Single-mode Fiber Output Power	P _o	I _{op}	10	—	—	mW
Center Wavelength	λ	I _{op}	1680	1690	1700	nm
Spectral Width (FWHM)	Δλ	I _{op}	45	—	—	nm

Spectral Ripple	R	Iop	—	—	0.5	dB
Thermistor Resistance	Rtherm	T = 25 °C	9.5	10	10.5	kΩ
TEC Voltage	VTEC	Iop	—	—	3	V
TEC Current	ITEC	Iop	—	—	1.8	A

TSLED temperature is monitored by the internal thermistor.

Absolute Maximum Ratings

Parameter	Symbol	Condition	Min.	Max.	Unit
Reverse Voltage	VR	—	—	2	V
Forward Current	IF	—	—	450	mA
Forward Voltage	VF	Iop	—	3	V
Case Temperature	Tc	Iop	-40	65	°C
SLED Temperature	TSLED	Iop	0	70	°C
TEC Voltage	VTEC	—	—	3.56	V
TEC Current	ITEC	—	—	2.6	A
Storage Temperature	Tstg	Unbiased	-40	85	°C



Storage Humidity	—	—	5	85	%RH
ESD Withstand Voltage	VESD	Human Body Model	—	500	V
Lead Soldering Temperature	Stemp	—	—	260	°C
Lead Soldering Duration	Stime	—	—	10	sec

Typical Performance Characteristic Curves

(Operating condition: T SLED = 25° C)

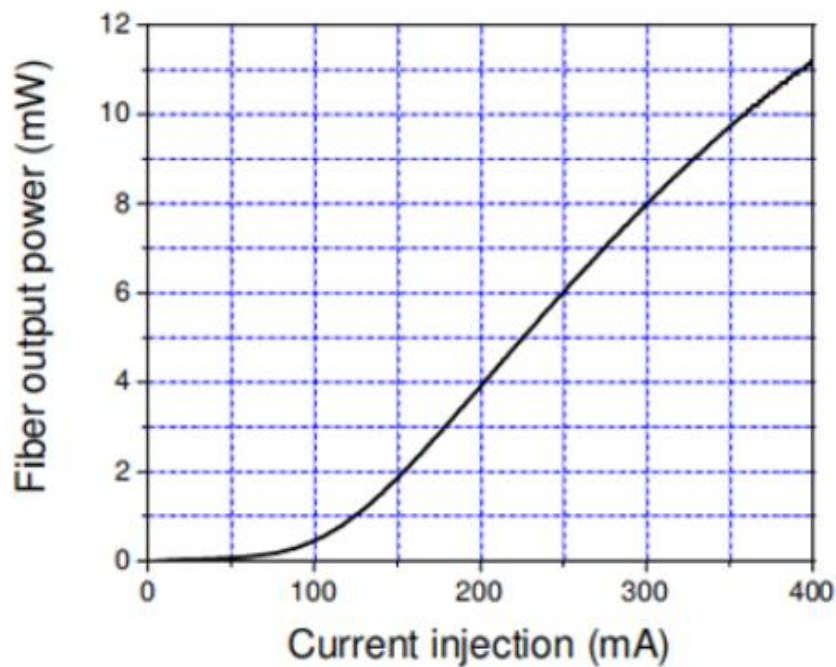

P-I Curves

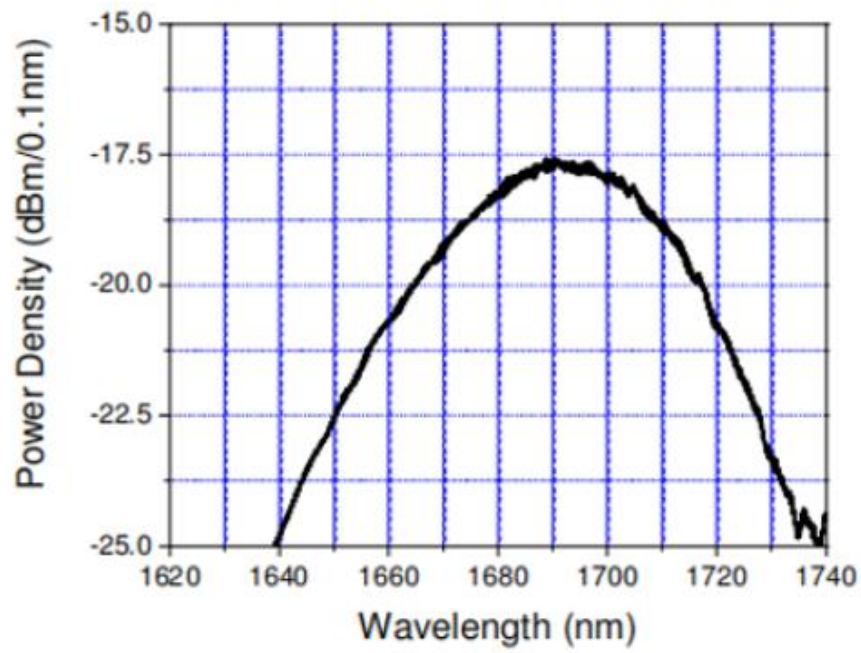

Spectrum

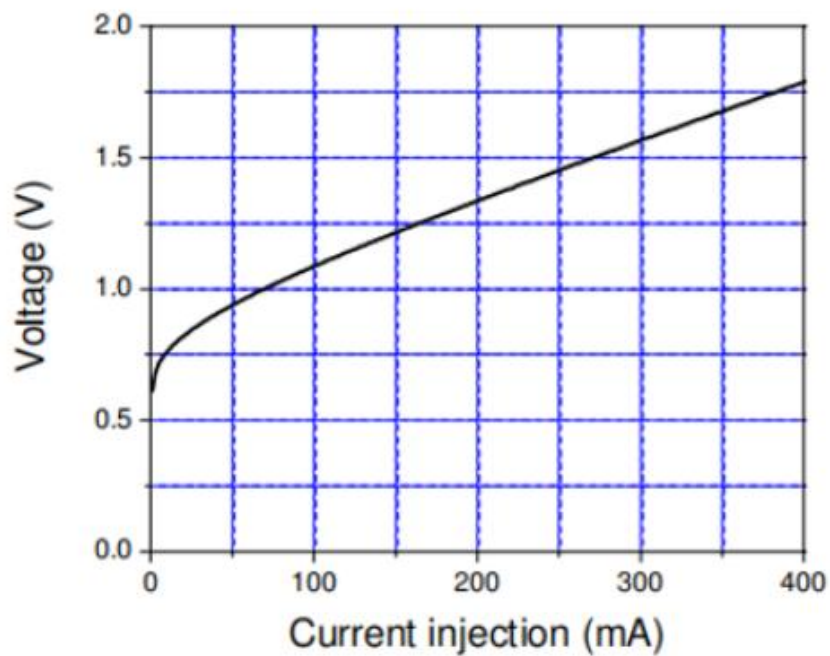

I-V Curves

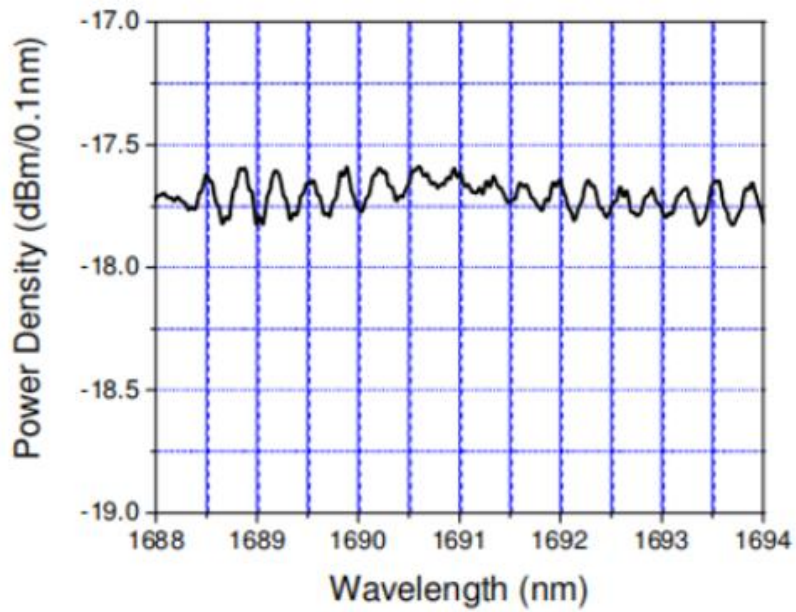

Spectral Modulation

BTF Package

Parameter	Description
Package Type	BTF
Fiber Type	SMF-28
Mode Field Diameter (MFD)	10 μm
Cladding Diameter	125 μm
Coating Diameter	245 μm
Protective Sleeve	900 μm loose tube



Pigtail Length	1 m
Fiber Bending Radius	>40 mm
Connector Type	FC/APC
Dimension Information	Refer to the figure below

Pin Assignment	
1	TEC+
2	THERMISTOR
3	-
4	-
5	THERMISTOR
6	-
7	-
8	-
9	-
10	SLED ANODE +
11	SLED CATHODE -
12	-
13	CASE
14	TEC -

