

850nm 1mW TO46 SM VCSEL Laser Diode(with TEC)



● Product Description

Featuring optimized optical properties, the 850 nm single-mode VCSEL is an ideal selection for high-demand sensing system applications. Its innovative chip design suppresses high-order longitudinal and transverse modes while delivering stable linear polarization performance.



● Product features

Vertical-cavity surface-emitting laser structure ; Integrated TEC (Thermoelectric Cooler) for precise temperature control ; Low power consumption and high efficiency; T046 metal hermetic package; High-speed modulation capability

● Part Number

MP-VCS-850-1-T046-SM-TEC

● Application area

High-Speed Optical Communication | Optical Fiber Sensing | 3D Sensing |
Industrial Control | Quantum Technology

● Core parameters

Center Wavelength
850nm



● Dimension Drawing

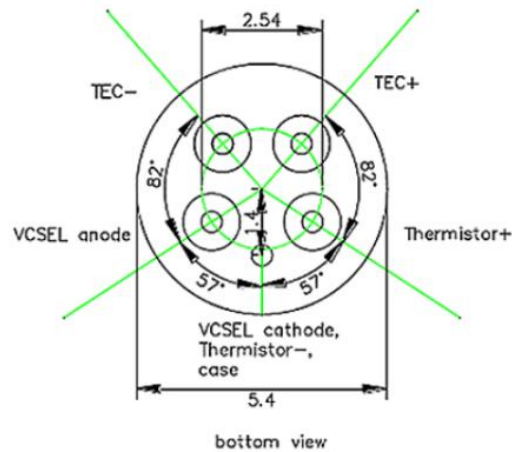
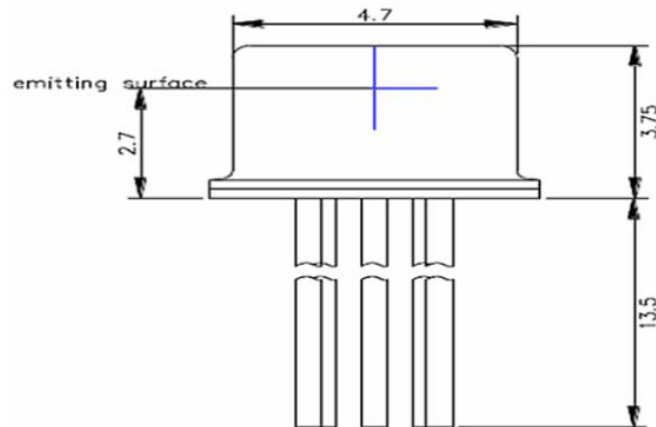

● General Parameters

Model parameters

Parameters	symbol	Min. value	Typical values	Max. value	unit	Note:
Incident wavelength	λ_R	840	850	860	nm	T = 20°C, I _{TEC} = 0, P _{OP} = 0.5



						mW
Threshold current	I_{TH}		0.50		mA	T = 20°C
Output power	P_{opt}	0.50			mW	T = 0 ... 50°C
Threshold voltage	U_{TH}		1.80		V	
Laser current	I_{OP}			2.0	mA	$P_{opt} = 0.5$ mW
Laser voltage	U_{OP}		2.0		V	$P_{opt} = 0.5$ mW
Electro-optical conversion rate	η_{WP}		12		%	$P_{opt} = 0.5$ mW
Slope performance	η_s		0.3		W/A	T = 20°C
Differential series resistors	R_s		250		Ω	$P_{opt} = 0.5$ mW
3dB modulation bandwidth	v3dB	0.10			GHz	$P_{opt} = 0.5$ mW (Due to ESD protection diodes)
Relative noise intensity	RIN		-130	-120	dB/H z	$P_{opt} = 0.3$ mW @ 1 GHz
Wavelength-tuned current			0.6		nm/ mA	
Wavelength Tuning Temperature			0.06		nm/ K	
Thermal resistance	R_{therma}	3		5	K/m	



	l				W	
Edge mode suppression		30			dB	
Beam divergence	θ	10		25	$^{\circ}$	$P_{opt} = 0.5 \text{ mW}$ full $1/e^2$ bandwidth
Spectral bandwidth	$\Delta\nu$		100		MHz	$P_{opt} = 0.5 \text{ mW}$
TEC current	I_{TEC}			500	mA	Proper radiator is required
NTC thermistor		9.5	10.0	10.5	k Ω	$T = 25^{\circ}\text{C}$,
NTC temperature dependence		$10/\exp[3892 \cdot (1/298\text{K} - 1/T_0)]$			k Ω	
Wavelength tuning TEC current		0.008			nm/ mA	TEC current < 200 mA

Absolute maximum

- Storage temperature -40~125°C
- Operating temperature -20~80°C
- Electrical power loss of 5 mW

- Forward laser current 2 mA
- Reverse current 10 mA
- Welding temperature* 270C°
- *TEC temperature must be below 150°C

Spectral diagram

Higher-order modes are strongly suppressed and the spectral bandwidth is extremely narrow

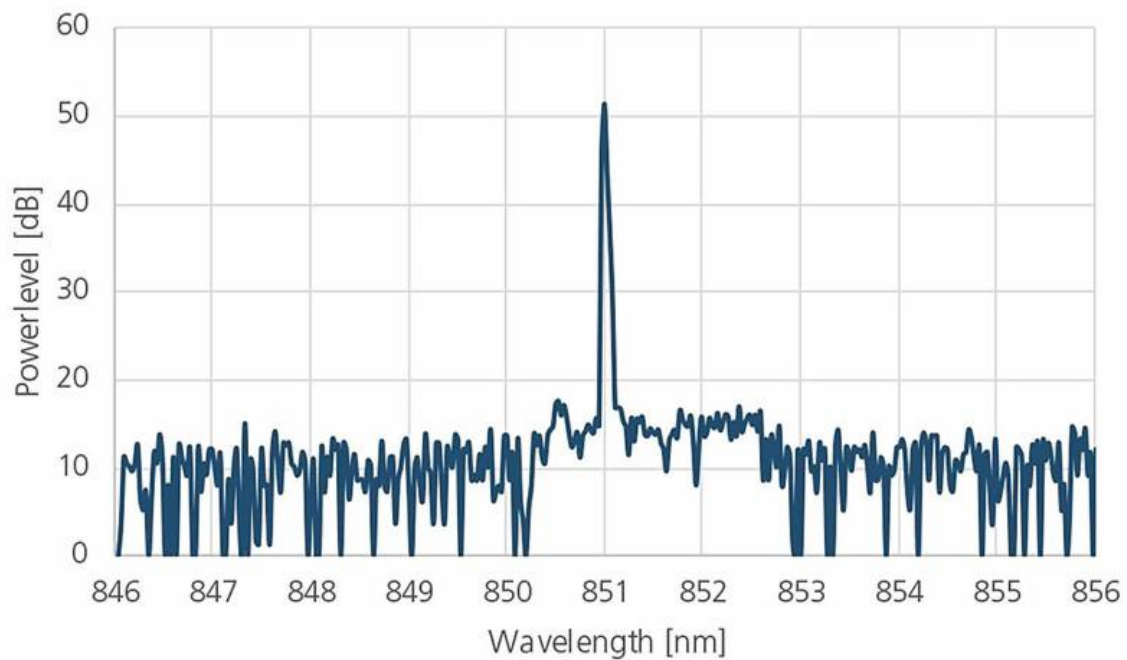

Beam profile

The far-field light intensity distribution of single-mode VCSEL is complete in accordance with the Gaussian mode

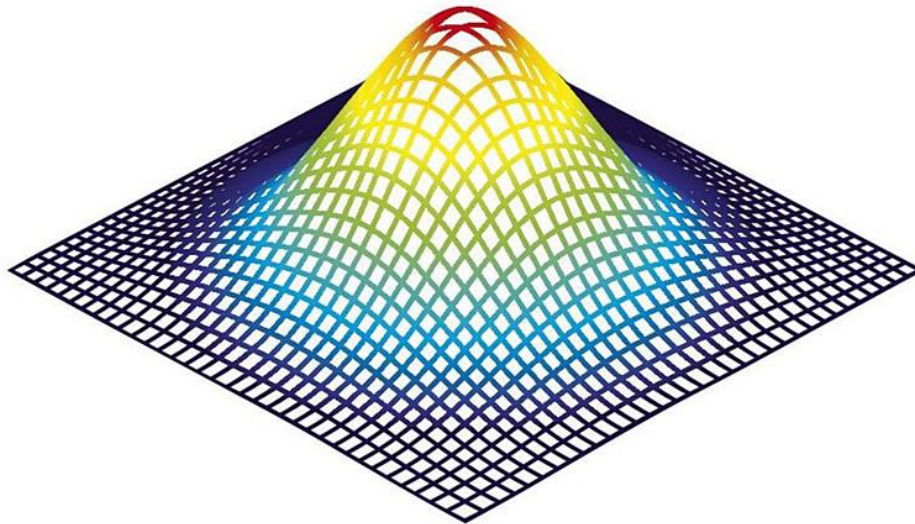

LIVT characteristic curves

You will benefit from linear performance and low threshold currents over a wide temperature range

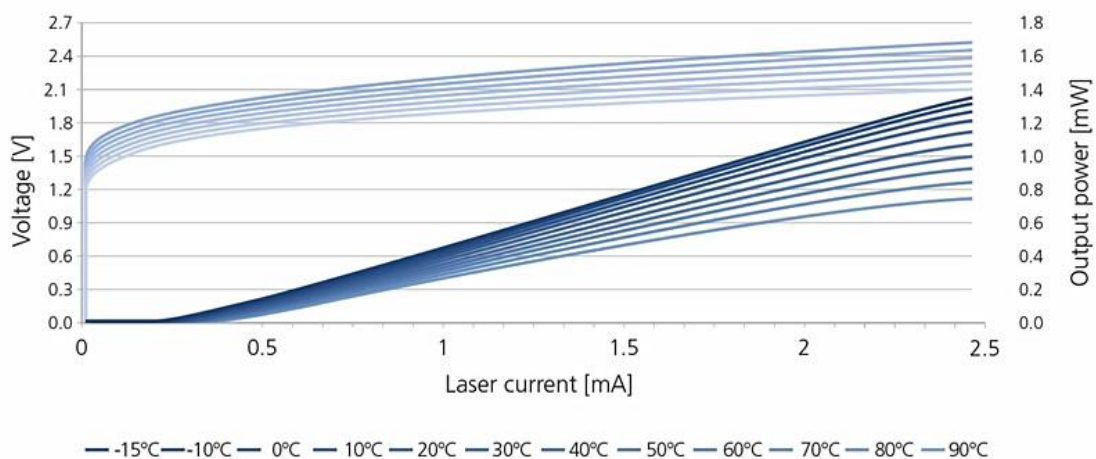

Temperature/wavelength under TEC current tuning

