

# 1060nm High-Gain Semiconductor Optical Amplifier

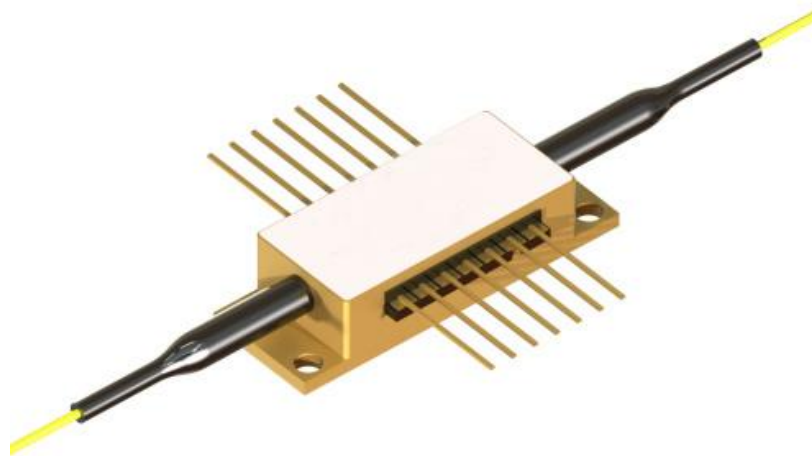

## ● Product Description

A high gain semiconductor optical amplifier designed for the 1060nm wavelength band. By using proprietary anti reflection coatings, tilted waveguides, and other designs, high fidelity and high gain amplification of weak optical signals can be achieved. This series of products has high saturation output power, low noise figure, and high polarization extinction ratio characteristics, and provides two solutions: narrowband (high gain) and broadband (large bandwidth), suitable for scientific research experiments and commercial fiber optic systems



- **Product features**

High gain coefficient; narrowband optimized amplification; low-power operation; excellent signal-to-noise ratio; superior temperature stability

- **Part Number**

MP-SOA-1060-40db-22-XA

- **Application area**

Precision laser measurement | quantum optics experiment | fiber optic sensing system | medical diagnostic equipment | research-grade optical system

- **Core parameters**

Operating Wavelength	Operating Bandwidth
1060nm	22nm

## ● Dimension Drawing

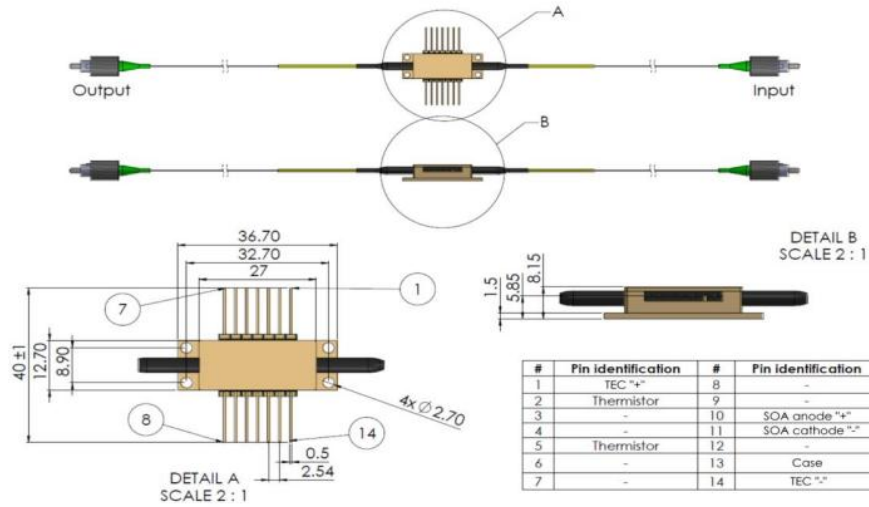

## ● General Parameters

Detailed Specifications

Recommended Operating Conditions

@ CW, housing mounted on a heat sink at room temperature

Parameter	Min.	Typ.	Max.	Unit
Chip Temperature	20	25	30	°C
Forward Current	—	450	500	mA
Input Optical Power	-40	-25	10	dBm

\* The current for maximum gain spectral width may vary by batch.



## Gain Characteristics

@ CW, 25°C, 450 mA, input signal: -25 dBm at maximum gain wavelength

Parameter	Min.	Typ.	Max.	Unit
Small-Signal Gain @ 400 mA	36	39	—	dB
Saturated Output Power @ 400 mA (-3 dB)	15	18	—	dBm
Average Gain Wavelength	1050	1060	1070	nm
Gain Bandwidth (FWHM)	15	22	—	nm
Noise Figure	—	8	—	dB

Noise Figure Formula :

$$NF=10\log_{10}(2P_{ase}/Ghv)$$

[D. Baney et al., Fiber Technology, 6, 122 (2000)]

# Amplified Spontaneous Emission (ASE) Characteristics

@ CW, 25°C, 450 mA, no input signal

Parameter	Min.	Typ.	Max.	Unit
Output Power (Per Port)	—	60	—	mW
Forward Voltage	—	1.6	1.9	V
Average Wavelength	1050	1060	1070	nm
Bandwidth (FWHM)	15	21	—	nm
Ripple (RMS)**	—	0.07	0.3	dB
Polarization Extinction Ratio (PER)	15	18	—	dB
Polarization	—	TE	—	—

\*\* Measured within 1 nm range near the spectral peak with 20 pm resolution.



## Absolute Maximum Ratings

Parameter	Min.	Max.	Unit
Output Optical Power	—	600	mW
Input Optical Power	—	20	dBm
Forward Current	—	800	mA
Reverse Voltage	—	2	V
TEC Current	—	3	A
TEC Voltage	—	4	V
Chip Operating Temperature	10	40	°C
Housing Operating Temperature	0	70	°C
Storage Temperature	-40	85	°C
Lead Soldering Temperature (Max. 10 s, max housing temperature 120 °C)	—	300	°C
Fiber Bend Radius	—	3	cm

## Typical performance (for reference only)

@CW, the case is mounted on room temperature heatsink

Gain spectra at different currents

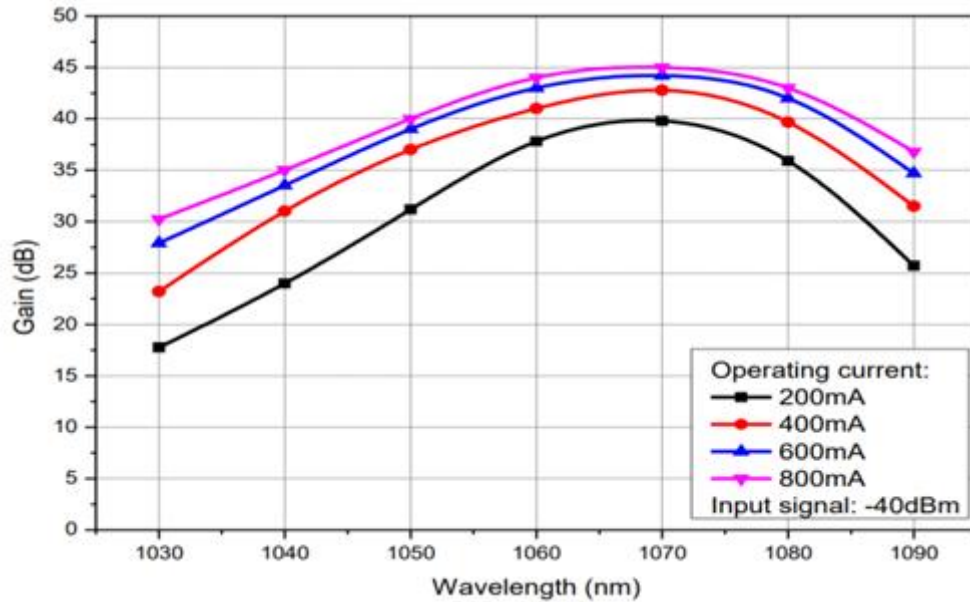

Gain and Output power vs. Input signal

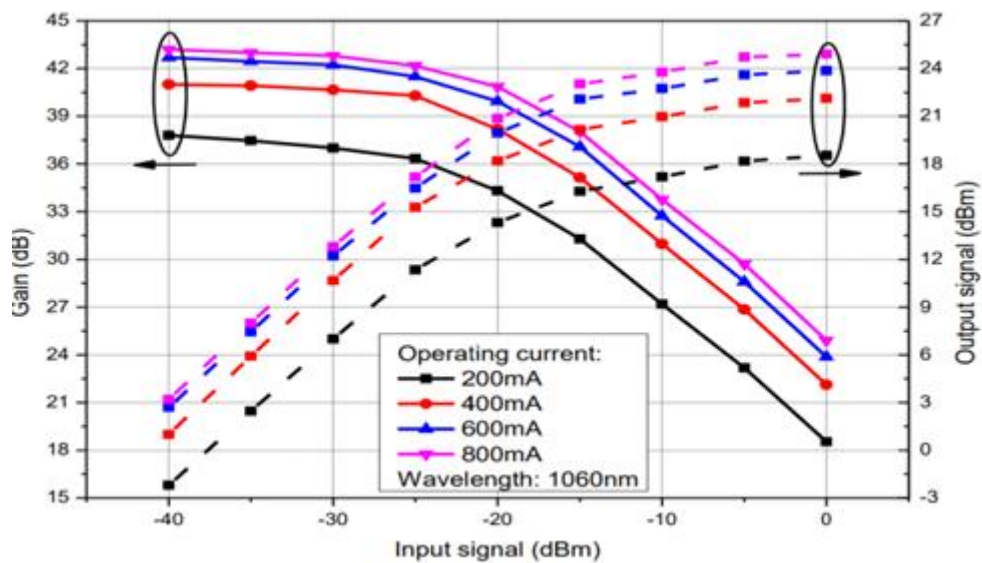

### Gain spectra at different input signals

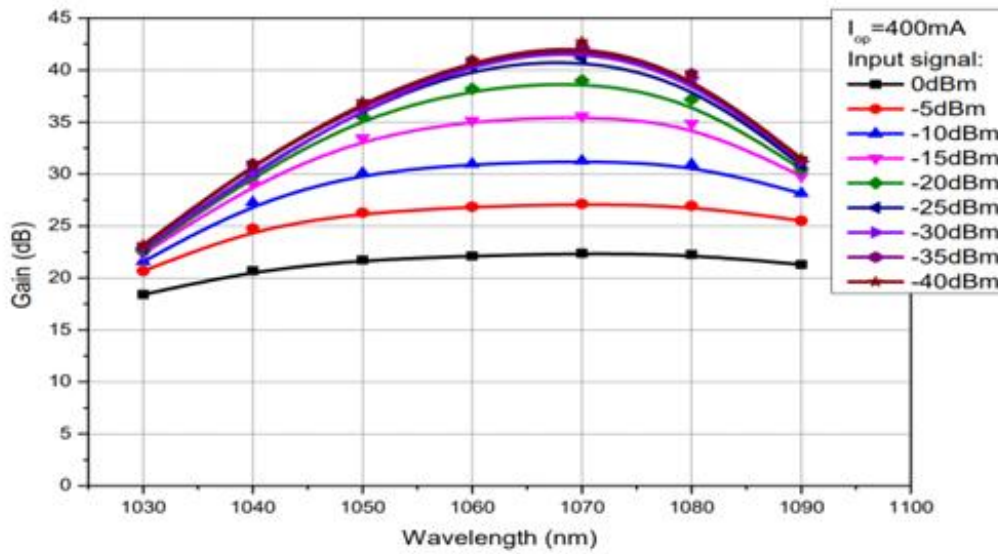

### Spectra of amplified optical signal

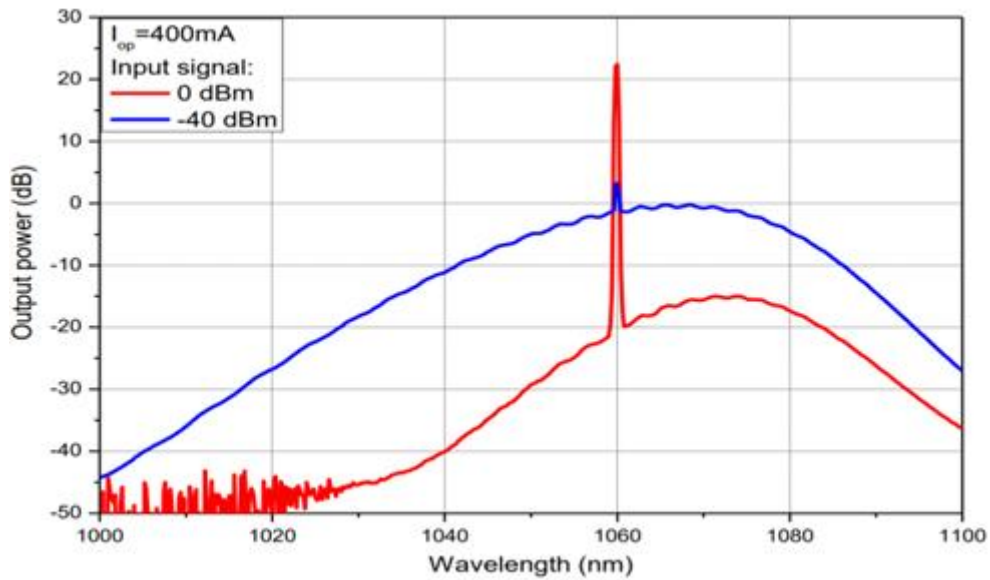

### ASE spectra(no input signal)

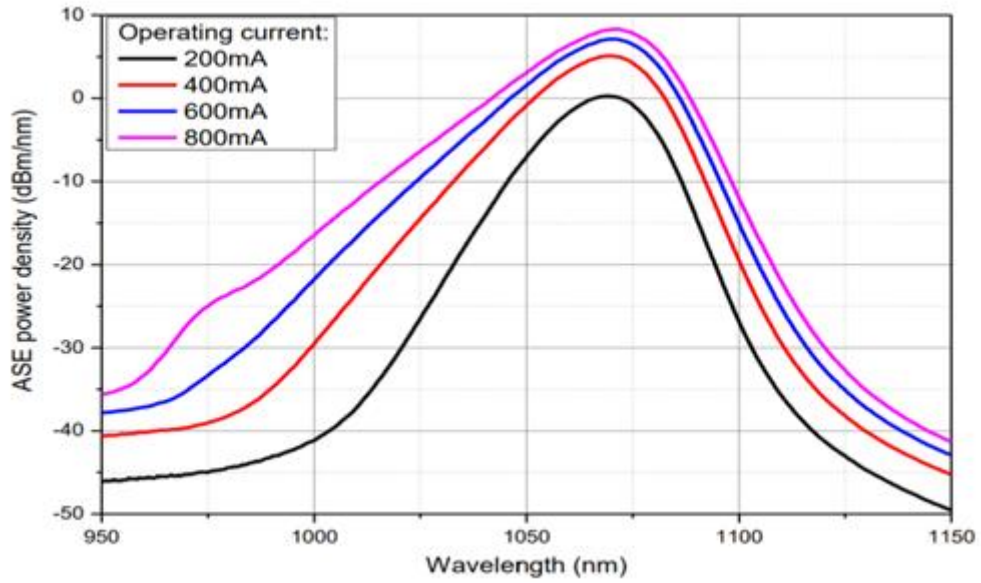

### Output power at different input signals

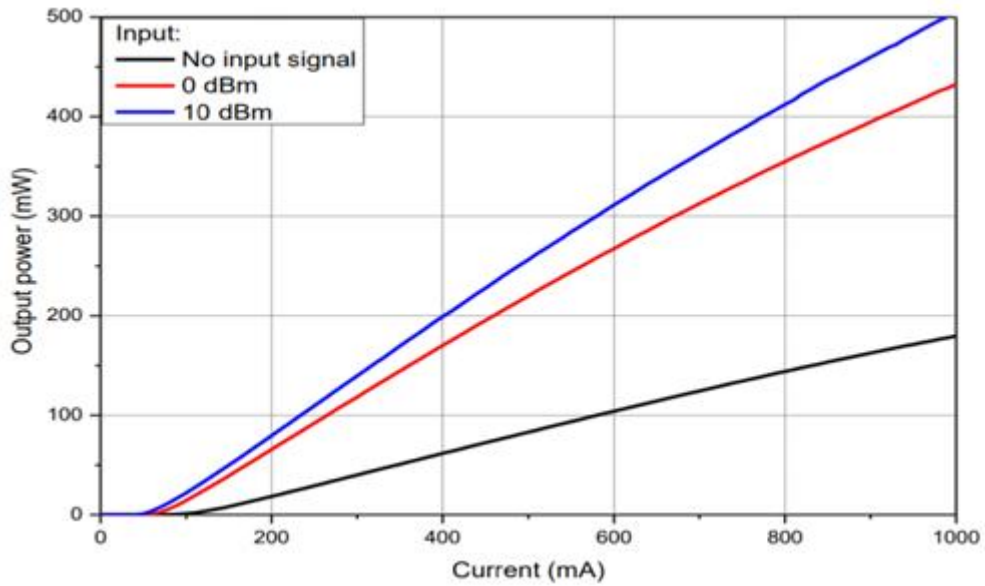

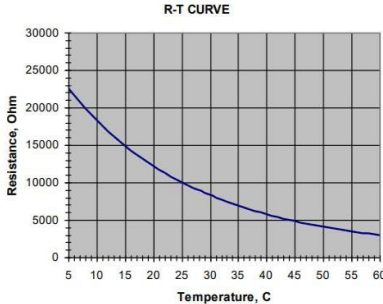
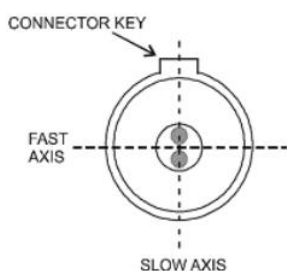

Thermistor Specifications			Fiber Specifications			
Parameter	Value	Unit	Parameter	PM980	HI1060	Unit
Type	NTC	—	Numerical Aperture, typical	0.12	0.14	—
Resistance @ 25 °C	10 ± 0.1	kΩ	Cutoff Wavelength	900 ± 70	920 ± 50	Nm
Beta (25–85 °C)	3435 ± 1%	K	Mode Field Diameter (@ 1060 nm)	6.6 ± 0.3	6.2 ± 0.3	μm
			Cladding Diameter	125 ± 1	125 ± 1	μm
			Coating Diameter	245 ± 15	245 ± 15	μm
			Loose Tube Diameter (Optional)	900	900	μm
			Connector	FC/APC (narrow key)		
			Connector Alignment aligned with PANDA fiber			
			 <p>Output light is polarized along the slow axis of the PM fiber.</p>			

## **Operating Instructions Safety and Operating Instructions**

The light emitted by this device is invisible and harmful to human eyes. Do not look directly at the fiber connector during operation. Appropriate laser safety goggles must be worn when operating with the connector uncovered.

Absolute maximum ratings may only be applied to the device for a short time. Long-term operation at or simultaneous exposure to multiple maximum ratings may cause device damage and reduce reliability. Operation beyond the maximum ratings may lead to device failure and safety risks. A matched power supply shall be used to ensure that the maximum forward current is not exceeded.

Devices mounted on heat spreaders require a proper heat sink. Secure the device to the heat sink with four screws (cross-tightened with an initial torque of 0.075 N ·m and a final torque of 0.15 N ·m) or clamps. The flatness deviation of the heat sink surface shall be less than 0.05 mm. Indium foil or flexible thermal interface materials are recommended between the device base and the heat sink. Thermal grease is not recommended.

Avoid optical back-reflection, which may degrade spectral performance and power stability, and cause catastrophic facet damage. The use of an optical isolator is strongly recommended to suppress back-reflection.



Do not pull the optical fiber. Do not bend the fiber with a bending radius less than 3 cm. Protect the fiber end-face from contamination and damage during installation. After removing the dust cap, clean the fiber end-face in one direction with lens wipes or cotton swabs moistened with isopropyl alcohol or ethanol. Only operate the device with clean fiber connectors.

ESD Protection – Electrostatic discharge is a major cause of unexpected product failure. Strict ESD protection measures must be taken. Maintain ESD control during installation, including anti-static wristbands, grounded work surfaces and standardized anti-static operation procedures.

