

1310nm 20dBm BOA Fiber-Coupled Booster

Semiconductor Optical Amplifier

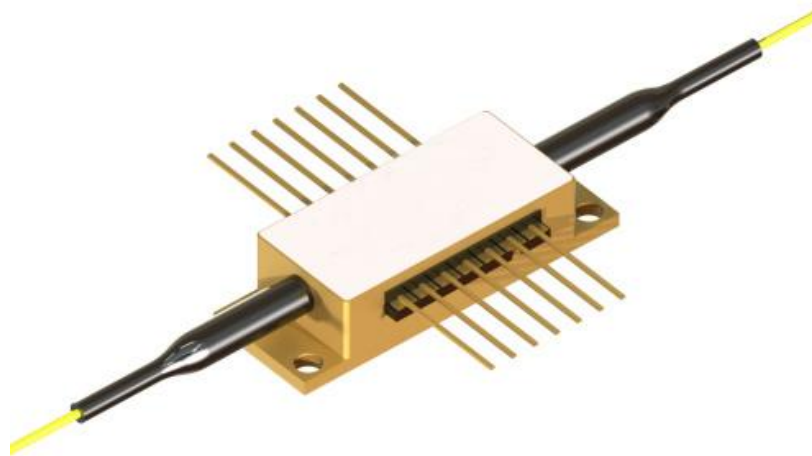

● Product Description

A high-power fiber coupled booster optical amplifier designed specifically for O-band (1260-1360nm) applications with a center wavelength of 1310nm. This product adopts advanced quantum dot gain materials and proprietary anti reflection coating technology, which can provide a saturated output power of up to 20dBm (typical value), and has a wide gain bandwidth of 70nm, suitable for various application scenarios that require high-power, broadband optical signal amplification.



- **Product features**

Fiber-coupled; high-power amplification; wide wavelength range; low noise;
compact package

- **Part Number**

MP-BOA-1310-100-70-XA

- **Application area**

Fiber Communication | Laser Processing | Sensing System | Medical Laser |
National Defense Technology

- **Core parameters**

Center Wavelength	Saturated Output Power@-3dB	Bandwidth@-3dB
1310nm	20dBm	70nm

● Dimension Drawing

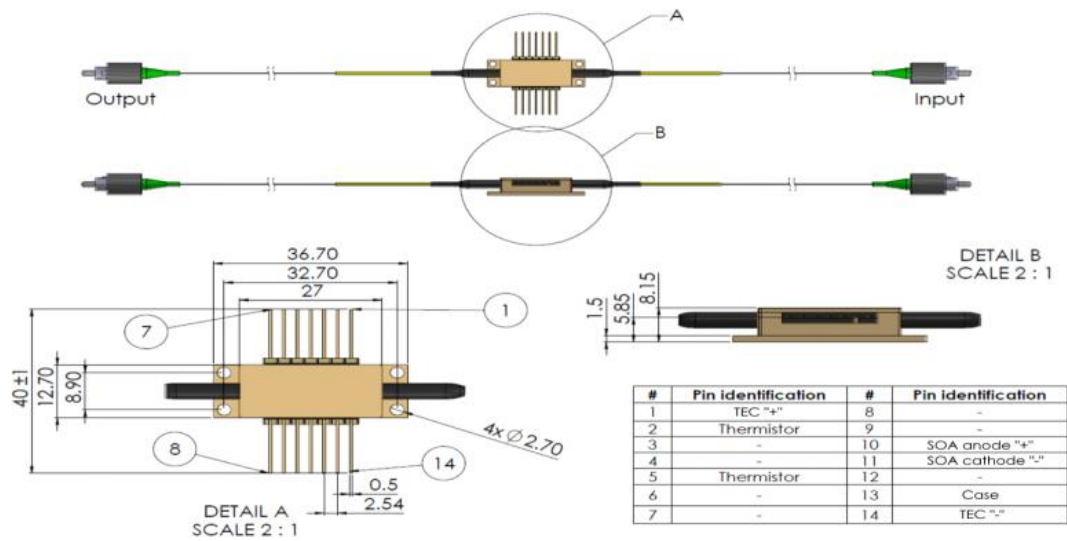

● General Parameters

Detailed Specifications

Recommended Operating Conditions

@ CW, Tcase = 25°C

Parameter	Min.	Typ.	Max.	Unit
Chip Temperature	20	25	40	°C
Forward Current	—	2000	3000	mA
Output Power (Amplification Mode)	—	—	300	mW
Input Optical Power	-20	10	15	dBm



Gain Characteristics

@ CW, 25°C, 2000mA, Input Signal 10dBm, 1300nm

Parameter	Min.	Typ.	Max.	Unit
Forward Current @ 400mW	—	—	3000	mA
Saturation Output Power @ -3dB	16	20	—	dBm
Gain	12	16	—	dB
Small Signal Gain @ Pin = -20dBm	33	37	—	dB
Peak Wavelength	1295	1310	1320	nm
Bandwidth @ -3dB	—	70	—	nm
Noise Figure @ Pin = -20dBm	—	6	—	dB



ASE Characteristics

@ CW, 25°C, 2000mA, No Input Signal

Parameter	Min.	Typ.	Max.	Unit
Output Power (Per Port)	—	70	—	mW
Forward Voltage	—	1.7	2.2	V
Average Wavelength	—	1210	—	nm
Bandwidth (FWHM)	—	16	—	nm
Ripple (RMS)**	—	0.02	1	dB
Polarization Extinction Ratio (PER)	13	18	—	dB
Polarization	—	TE	—	—

** Measured within 1nm range near the spectral maximum with 20pm resolution



Absolute Maximum Ratings

Parameter	Min.	Max.	Unit
Output Optical Power	—	800	mW
Input Optical Power	—	20	dBm
Forward Current	—	3500	mA
Reverse Voltage	—	2	V
TEC Current	—	3	A
TEC Voltage	—	4	V
Chip Operating Temperature	5	50	°C
Case Operating Temperature	0	50	°C
Storage Temperature	0	50	°C
Lead Soldering Temperature (10s max, Max. Case Temp 120°C)	—	300	°C
Fiber Bend Radius	3	—	cm

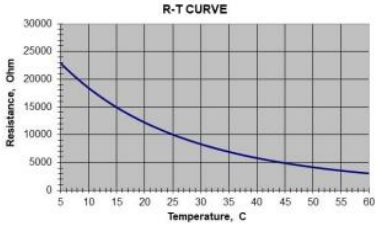
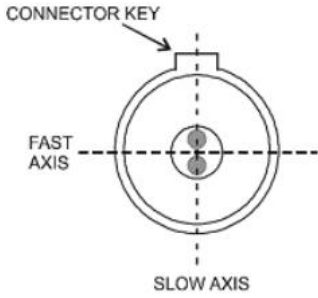

Thermistor Specifications			Fiber Specifications				
Parameter	Value	Unit	Parameter	PM980	HI1060	Unit	
Thermistor Type	NTC	—	Numerical Aperture, typical	0.12	0.14	—	
Resistance @ 25 °C	10 ± 0.1	kΩ	Cutoff Wavelength	900 ± 70	920 ± 50	Nm	
Beta (25–85 °C)	3434 ± 1%	K	Mode Field Diameter (@ 1060 nm)	6.6 ± 0.3	6.2 ± 0.3	μm	
			Cladding Diameter	125 ± 1	125 ± 1	μm	
			Coating Diameter	245 ± 15	245 ± 15	μm	
			Loose Tube Diameter (Optional)	900	900	μm	
			Connector	FC/APC (narrow key)			
			Connector Alignment aligned with PANDA fiber				
							
			<p>Output light is polarized along the slow axis of the PM fiber.</p>				



Characteristic Curves Typical Performance (For Reference Only)

@ CW, Tcase = 25°C

Output Power vs Operating Current

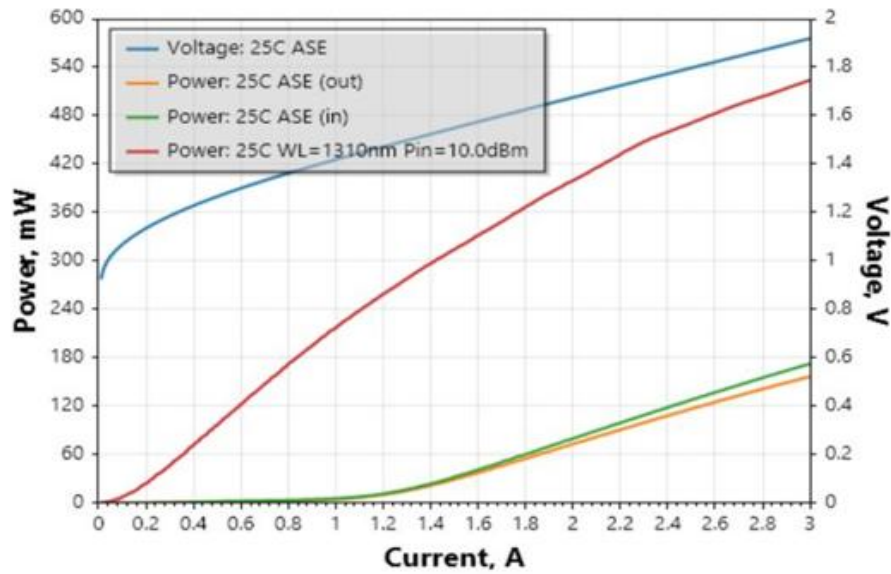

Gain Spectra

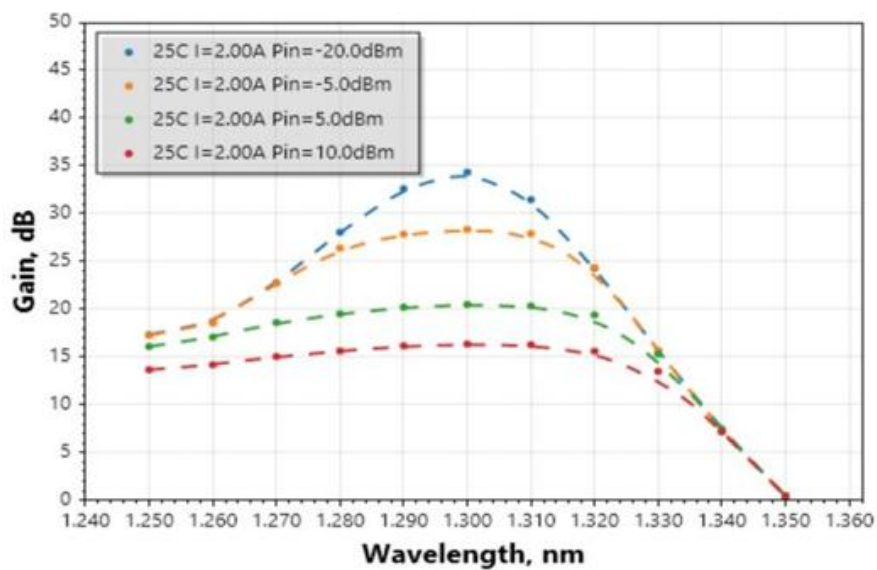



Gain vs Output Power

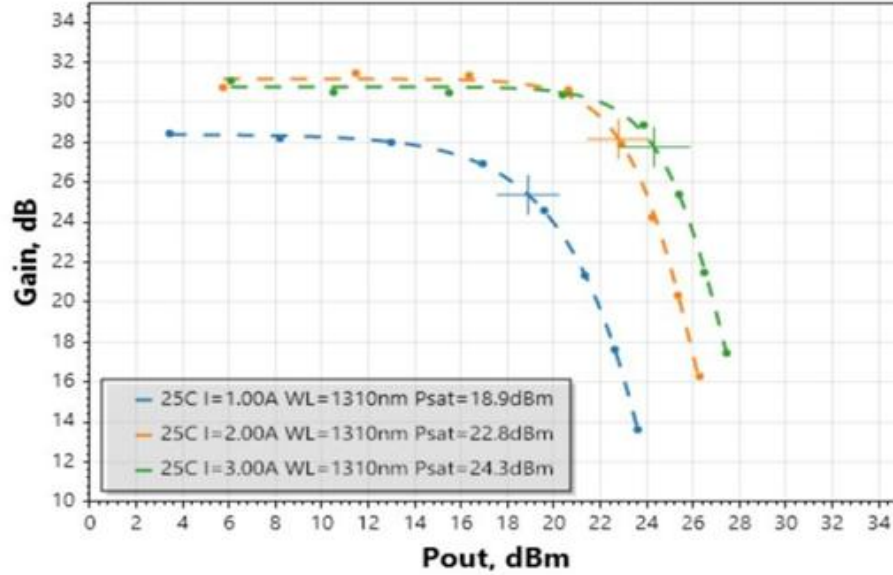

Output Power vs Input Power

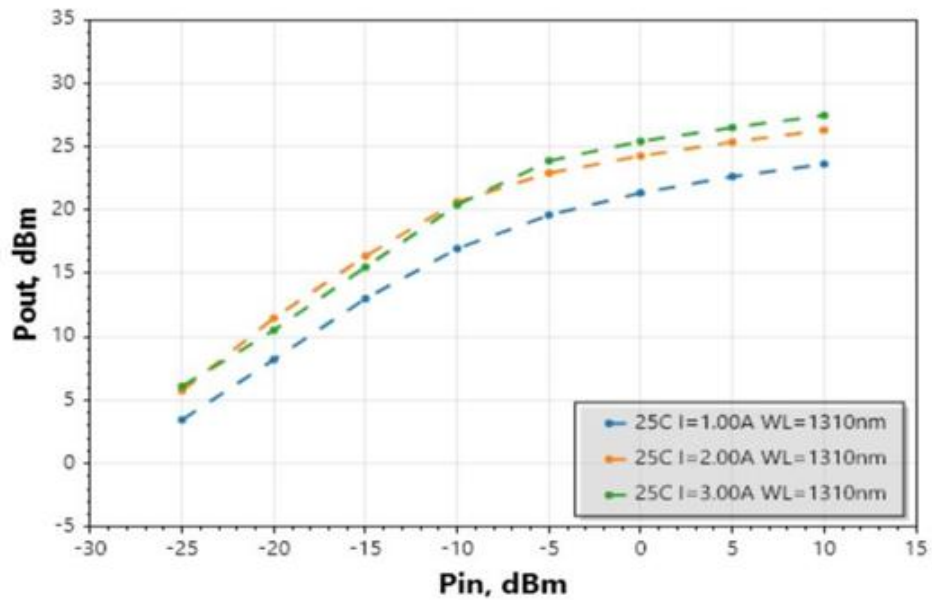

Optical Spectra of Amplified Optical Signals

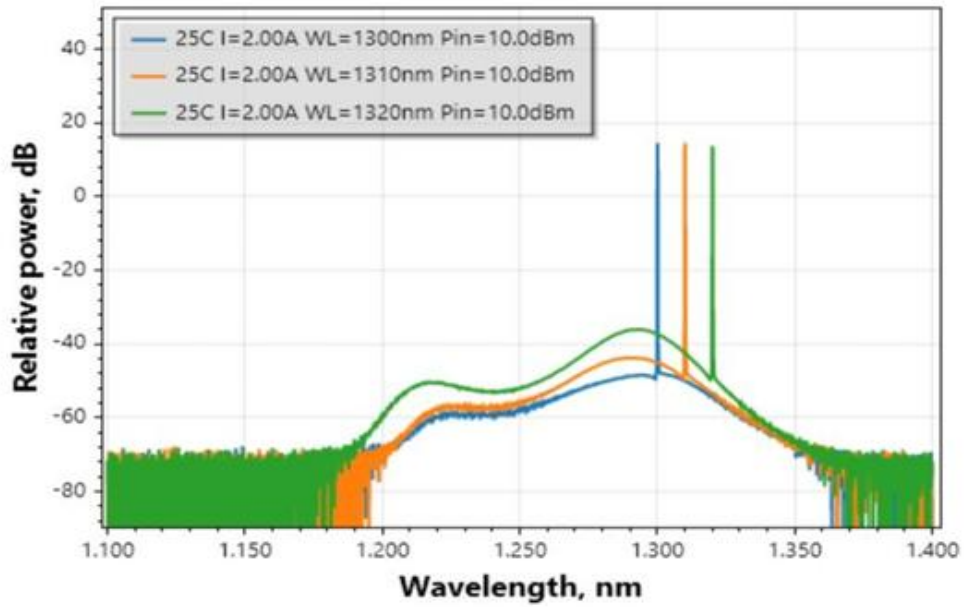

Optical Spectra(ASE)

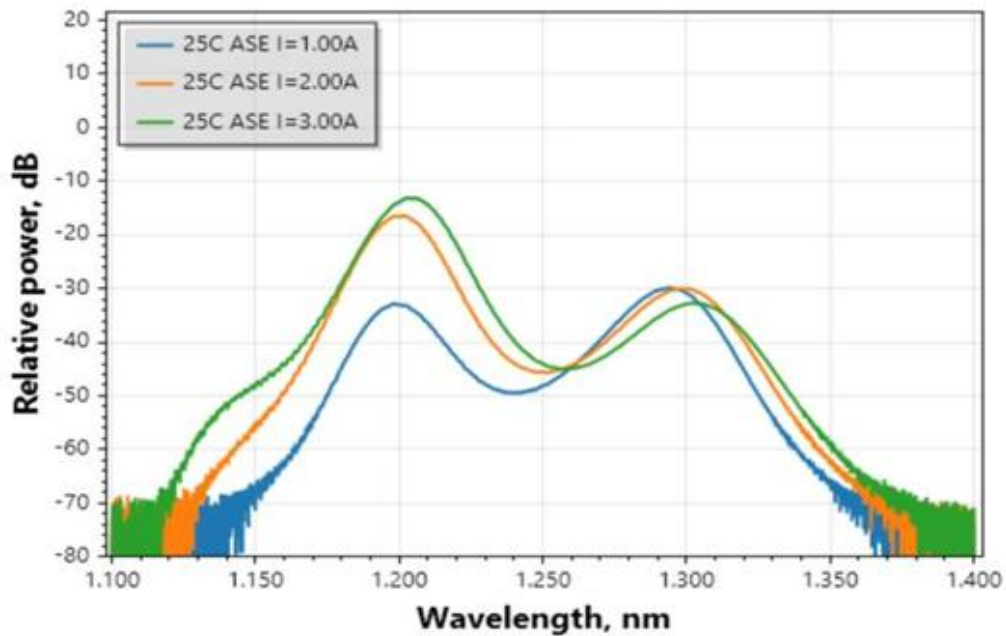

Safety and Operating Instructions

The light emitted by this device is invisible and harmful to human eyes. Avoid direct eye exposure to the fiber connector while the device is in operation. Proper laser safety goggles must be worn when operating with the connector open.

Absolute maximum ratings should only be applied to the device for short periods. Prolonged exposure to maximum ratings or exposure to multiple maximum ratings simultaneously may damage the device or impair its reliability. Operation beyond the absolute maximum ratings may result in device failure or safety hazards. A power supply suitable for the assembly must be used to ensure the maximum forward current is not exceeded.

Devices mounted on a heat radiator require an appropriate heat sink. The device must be installed on the heat sink using 4 screws (cross-tightened with an initial torque of 0.075 Nm and a final torque of 0.15 Nm) or a clamping mechanism. The flatness deviation of the heat sink surface must be less than 0.05 mm. The use of indium foil or a soft thermally conductive material as a thermal interface between the bottom of the package and the heat sink is recommended. Thermal grease is not suitable for this purpose.

Avoid back-reflection to the device. It may degrade the device performance in terms of spectral and power stability. It may also cause catastrophic facet



damage. The use of an optical isolator to suppress back-reflection is strongly recommended.

Do not pull the fiber. Do not bend the fiber with a radius smaller than 3 cm. The fiber tip shall be protected against contamination or damage at all times during installation. After removing the dust cap from the fiber tip, carefully clean it by wiping in one direction with optical lens cleaning paper or a cotton swab moistened with isopropyl alcohol or ethanol. Operate the device only with clean fiber connectors.

ESD Protection – Electrostatic discharge is a major cause of unexpected product failure. Extreme caution shall be taken to prevent ESD. ESD protection must be maintained during device installation – use wrist straps, grounded work surfaces, and strict anti-static techniques when handling the product.





Model Identification

BOA1310070HI300MXXX → Average wavelength 1310 nm, output power 300 mW, bandwidth 70 nm, HI-1060 fiber

BOA1310070PM300MLXXX → Average wavelength 1310 nm, output power 300 mW, bandwidth 70nm, PM-980 fiber with loose tube