



## 340nm 0.5mW UV LED Laser Diode



### ● Product Description

The 340nm LED is a deep ultraviolet LED with a peak emission wavelength from 335nm to 345nm. The LED is hermetically sealed in a metal-glass welded package. It incorporates advanced semiconductor materials, chip design, and a robust package with advanced optical properties. This is designed for optical sensing, medical, and analytical instrumentation for chemical and biological analysis in the deep UV spectral range.



- **Product features**

Deep UV band; Low power consumption; Compact package; Fast response;

Long lifetime

- **Part Number**

MP-LED-340-0.5-T039

- **Application area**

Surface sterilization | Water quality testing | Biological instruments |

Forensic detection | Ozone monitoring

- **Core parameters**

Center wavelength	Output power
340nm	0.5mW

## ● General Parameters

### Model Specifications

Parameter	Symbol	Min.	Typical	Max.	Unit	Remarks
Peak Wavelength	$\lambda$	335	340	345	nm	
TO Temperature	$T_{TO}$	-10		55	°C	
Chip Temperature	$T_{OP}$	20		55	°C	
Threshold	$I_{TH}$		0.5		mA	
Output Power	$P_{opt}$	0.3	0.5	1	mW	
Threshold Voltage	$U_{TH}$		5		V	
Laser Voltage	$U_{OP}$		6	7	V	
Drive Current	$I$		25	30	mA	
Beam Divergence	$\theta$		7		°	Full $1/e^2$ width
Spectral Bandwidth	$\Delta\nu$		11	15	nm	
Power Dissipation	$P_d$		180		mw	
Thermal Resistance( $T_j-T_{case}$ )[1]			50		°C/w	

#### Notes:

Storage temperature: -40~125°C

TO operating temperature: -40 ~85°C

Forward laser current: 30mA

Soldering temperature\*: 190°C

# Characteristic Curves

## Spectral graph

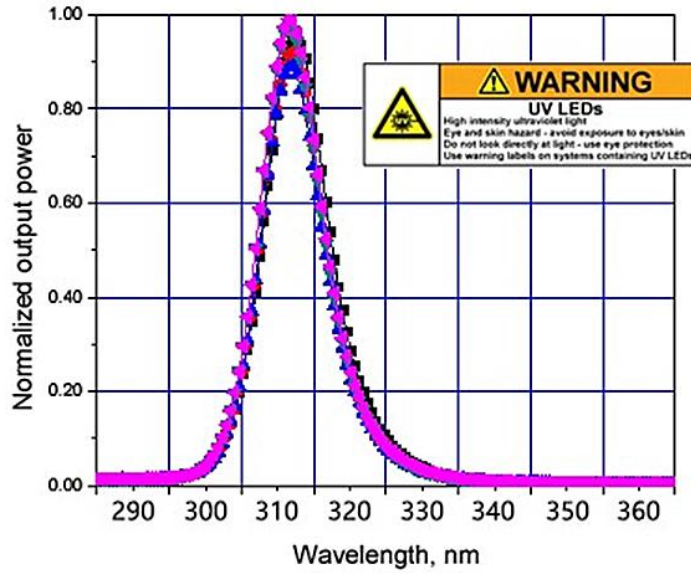

## LIV (Light-Current-Voltage) curve

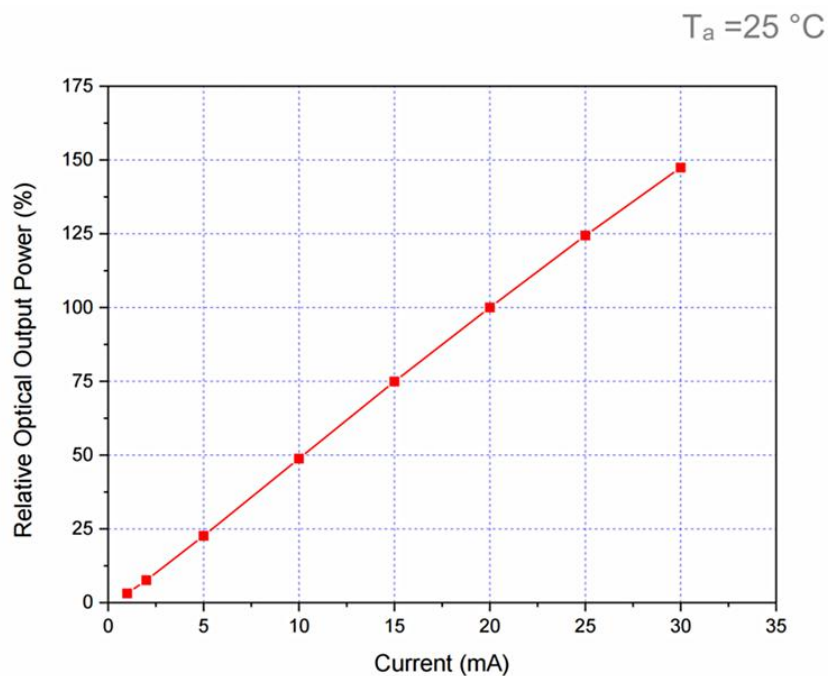

## Relative power vs. drive current curve

$T_a = 25\text{ }^\circ\text{C}$

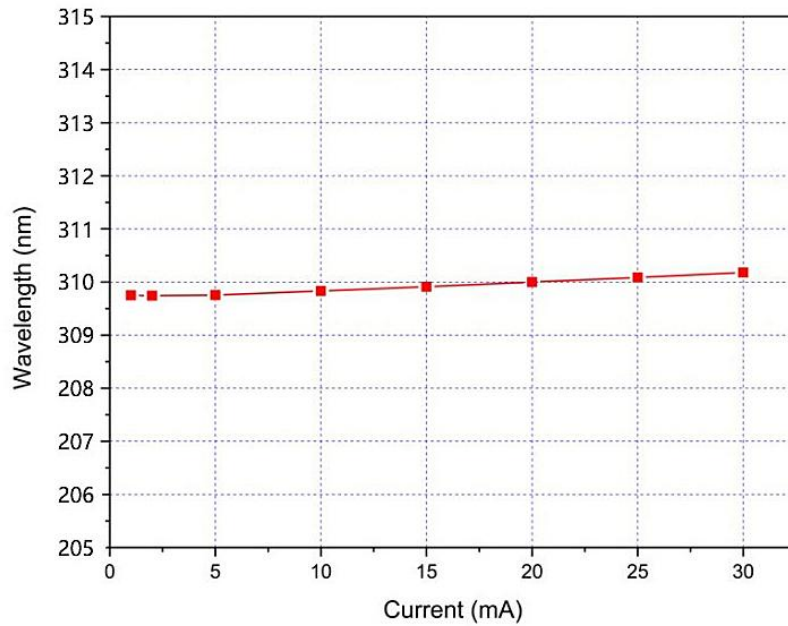

Drive current vs. wavelength curve

## Product Specifications

### Material Information:

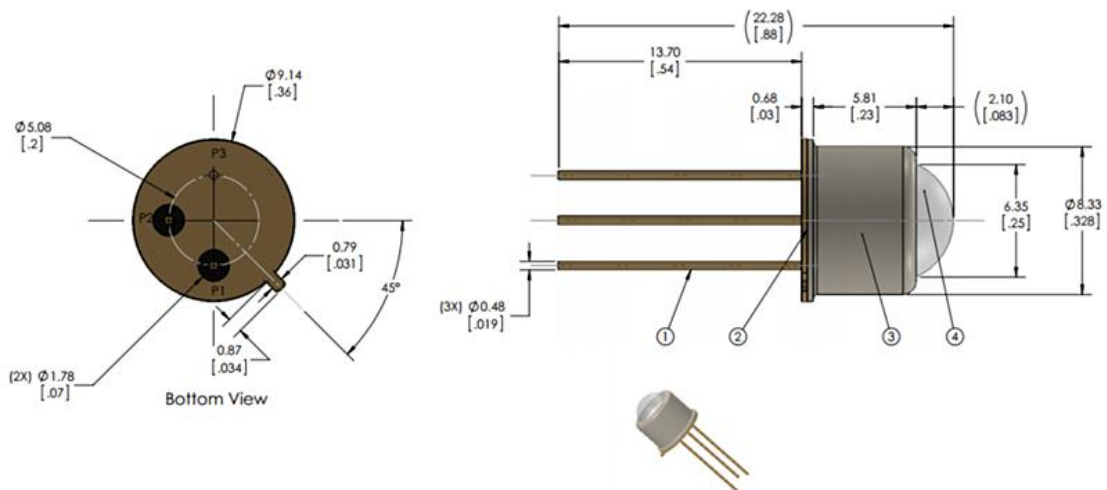



Material information	PIN#	Pin definition
1、 Gold-plated pin	P1	Anode(+)
2、 TO39 header	P2	Cathode(-)
3、 Gold cap	P3	Case
4、 Hemispherical lens		

**Note:**

[1] Dimensions in mm / [in]

[2] Not to scale

[3] Dimensions for reference only

[4] We reserve the right to change dimensions without notice

## Typical Divergence Angle Diagram

