



780nm single color LED Diode



- **Product Description**

The 780nm NIR emitter is designed for applications requiring high output and precise optical mechanical axis alignment. Custom package solutions and sorting are available.

- **Product features**

High Output Power; Narrow Beam Angle; High Reliability

- **Part Number**

MP-LED-780-7-TO18



● Application area

Bio Medical Applications | Optical Sensors | Optical Communications

● Core parameters

Center wavelength
780nm

● General Parameters

Absolute Maximum Ratings (Ta=25°C)

Items	Symbol	Ratings	Unit
Forward Current(DC)	IF	50	mA
Forwarded Current(Pulse)*1	IFP	0.5	A
Reverse Voltage	VR	5	V
Power Dissipation	PD	120	mW
Operating Temperature Range	Topr	-20 ~ +85	°C
Storage Temperature Range	Tstg	-30 ~ +100	°C
Lead Soldering Temperature*2	Tls	260	°C

*1: Tw=10μsec, T=10msec. *2: Time 5 Sec max, Position: Up to 3mm from the body.



Electrical & Optical Characteristics (Ta = 25°C)

Items	Symbol	Test Condition	Min.	Typical	Max.	Unit
Power Output	PO	IF=20mA	4.0	7.0	--	mW
Forward Voltage	VF	IF=20mA	--	1.57	1.90	V
Reverse Current	IR	VR=5V	--	--	100	μA
Peak Emission Wavelength	λ_p	IF=20mA	--	780	--	nm
Spectra Line Half Width	$\Delta\lambda$	IF=20mA	--	25	--	nm
Half Intensity Beam Angle	Θ	IF=20mA	--	± 8	--	°

Package Dimensions and Electro-Optical Characteristics

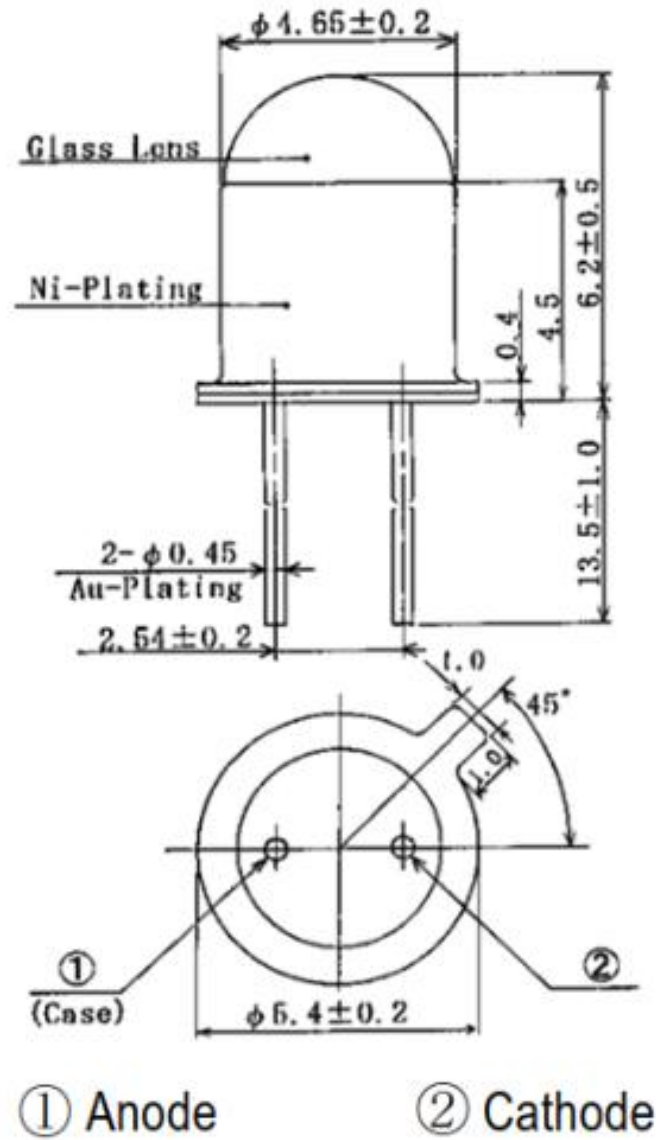



SPECTRAL OUTPUT

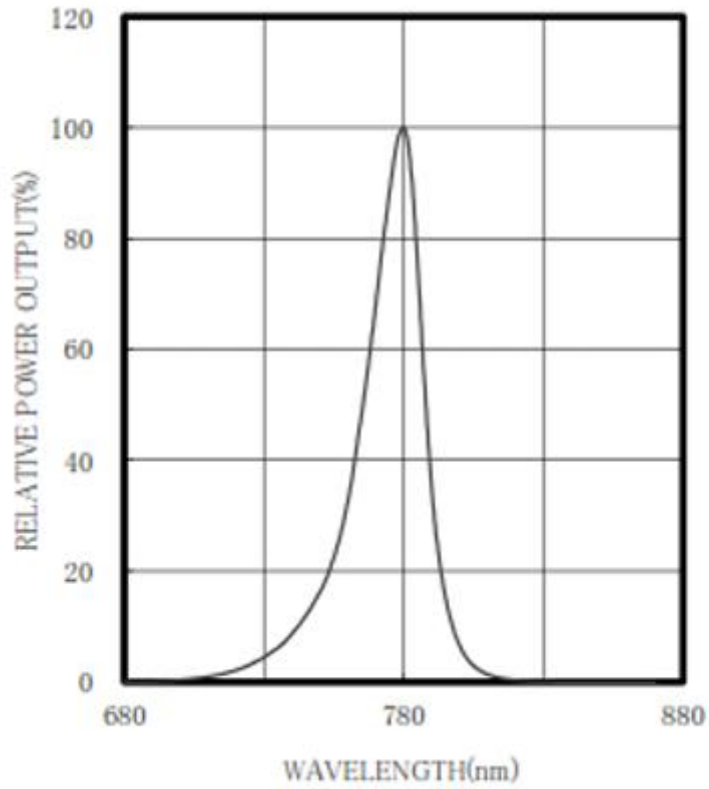

FORWARD I-V CHARACTERISTICS

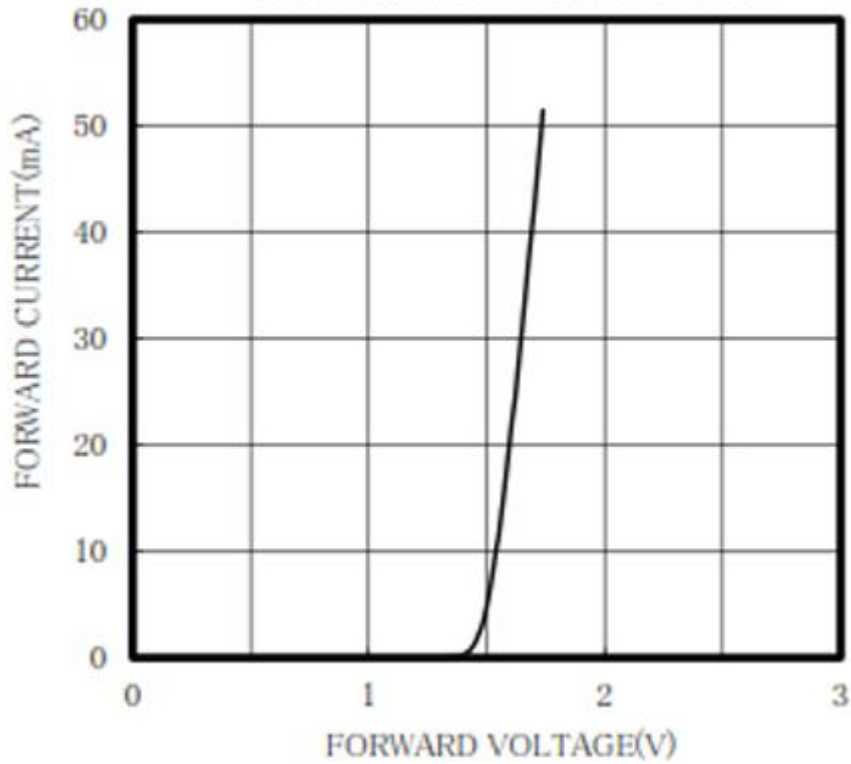

THERMAL DERATING CURVE

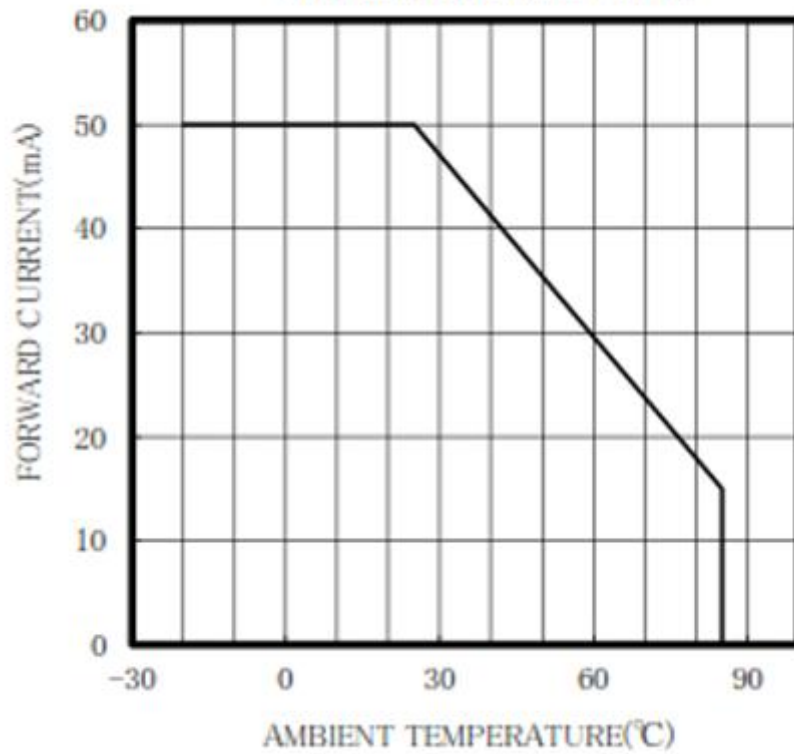

RELATIVE POWER vs FORWARD CURRENT

