

785nm 10mW SM FBG stabilized Tunable laser diode

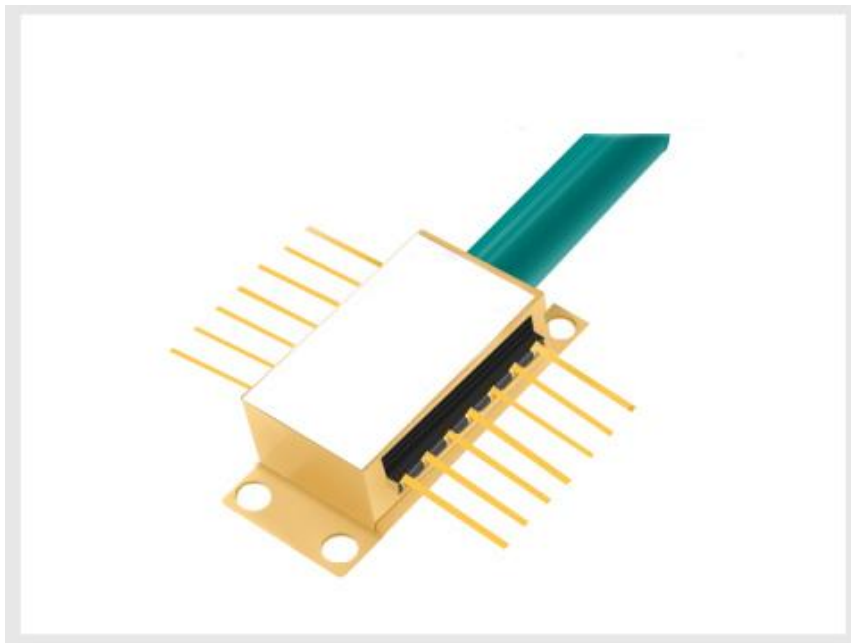

● Product Description

This series Fiber Bragg Grating laser is single frequency laser diode module designed for optical measurement and communication. The laser is packaged in 14-pin standard butterfly package with monitor photodiode and thermo-electric cooler (TEC). The Single-Frequency Continuous Tuning Range: > 1.2 nm by adjust the Mini PZT Built in the laser diode.



● Product features

Optical output: 10mW; Narrow linewidth ($\Delta\nu < 1\text{MHz}$); Wavelength: 785nm
@ 25 °C ; SM or PM Fiber ($\varnothing 0.9\text{mm}$) ; FC-APC connector ; 14-pin butterfly
package; Internal monitor PD and TEC; Low power consumption

● Part Number

MP-NL-785-A-A81-SA-PZT

● Application area

Laser interference experiment | Drop-side of DWDM long-haul transport
equipment | Optical Test and Instrumentation | Microwave Photonics | CATV
networks | Sensors

● Core parameters

Wavelength	Output Power	Fiber Type
785nm	10mW	SM



● General Parameters

Optical Characteristics (at 25 °C laser temperature)

Parameter	Symbol	Condition	Min.	Typical	Max.	Unit
Center Wavelength	λ_c	TL=15~ 35°C CW	780	785	790	nm
Peak Optical Output Power	PO	-	-	10	20	mW
Spectral linewidth	LW	-	-	1	10	MH Z
Side-mode Suppression Ratio	SMSR	CW	30	40	-	dB
Optical Isolation	-	-10 < TC < +70 °C	30	-	-	dB
Polarization Extinction Ratio	ER	-	20	-	-	dB
Relative Intensity Noise	RIN	CW, output power 5mW	-	-	-135	dB
Wavelength drift with case (-10 to 70 °C) temperature	$\Delta\lambda$	TL=15~ 35°C	-	-	± 30	pm
Tuning Range(For PZT Version)	Δf		0.5		1	nm
PZT Driving Voltage(PZT	VT		0		150	V



Version)						
Mode Hop free Range	ΔI			3		mA

Electrical Characteristics (at 25 °C laser temperature)

Parameter	Symbol	Condition	Min.	Typical	Max.	Unit
Threshold Current	ITH	-	-	45	65	mA
Operating Current	Iop	CW	-	80	100	mA
Slope Efficiency	η	CW output power 30 mW	0.06 4	0.1	0.4	mW/mA
TEC set temperature	Ts	-	15	-	35	°C
Laser Forward Voltage	VF	CW output power@3 0 mW	-	1.3	2.5	V
Input Impedance	ZIN		22	25	28	Ω
Monitor Dark Current	ID	-	-	-	0.1	μ A
Thermistor Current	ITC	-	10	-	100	μ A
Thermistor Resistance	RTH	TLD=25°C	9.5	10	10.5	K Ω
TEC Current	ITEC	TLD=25° C, TC=70	-	-	1.8	A



		°C				
TEC Voltage	VTEC	IF=EOL, TC=70°C	-	-	3.5	V
TEC capacity	ΔT	Tc = 70°C	-	-	50	°C
Thermistor temperature	-	-	-	-	100	°C

Spectrum

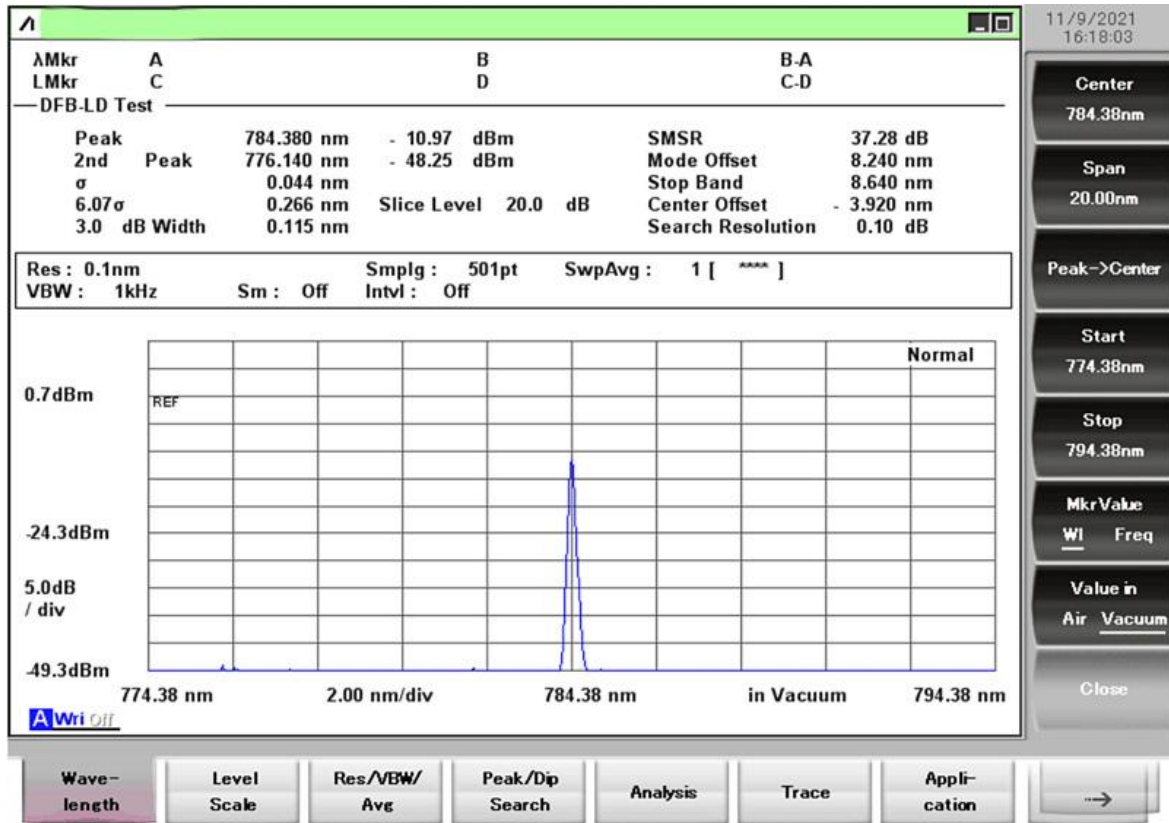

Voltage Vs Wavelength(PZT Version)

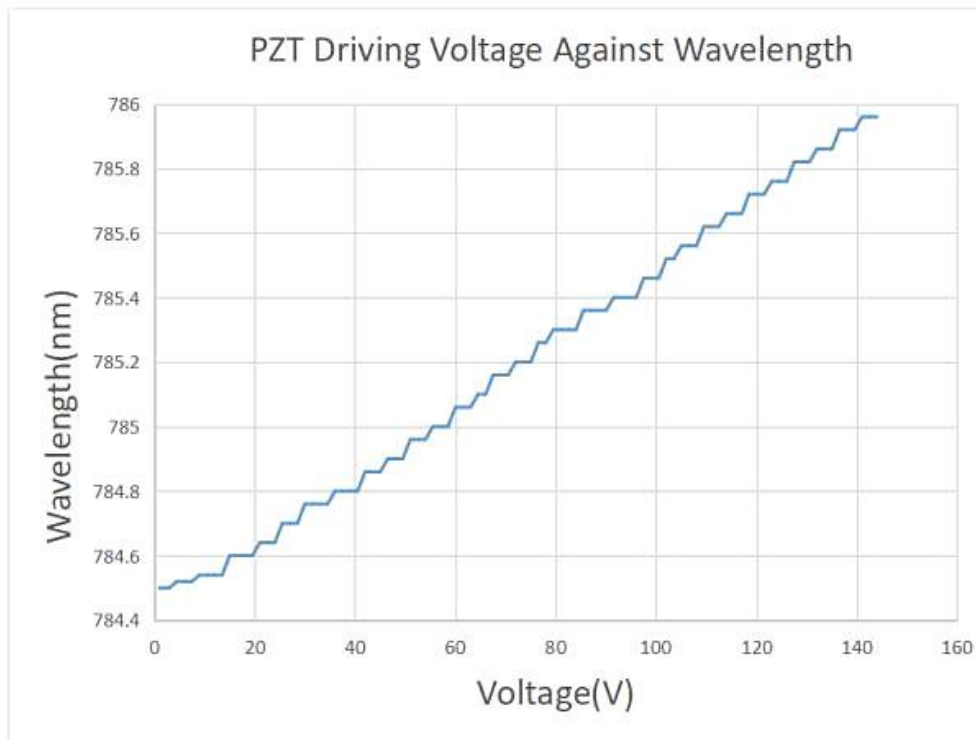

L-I Curve

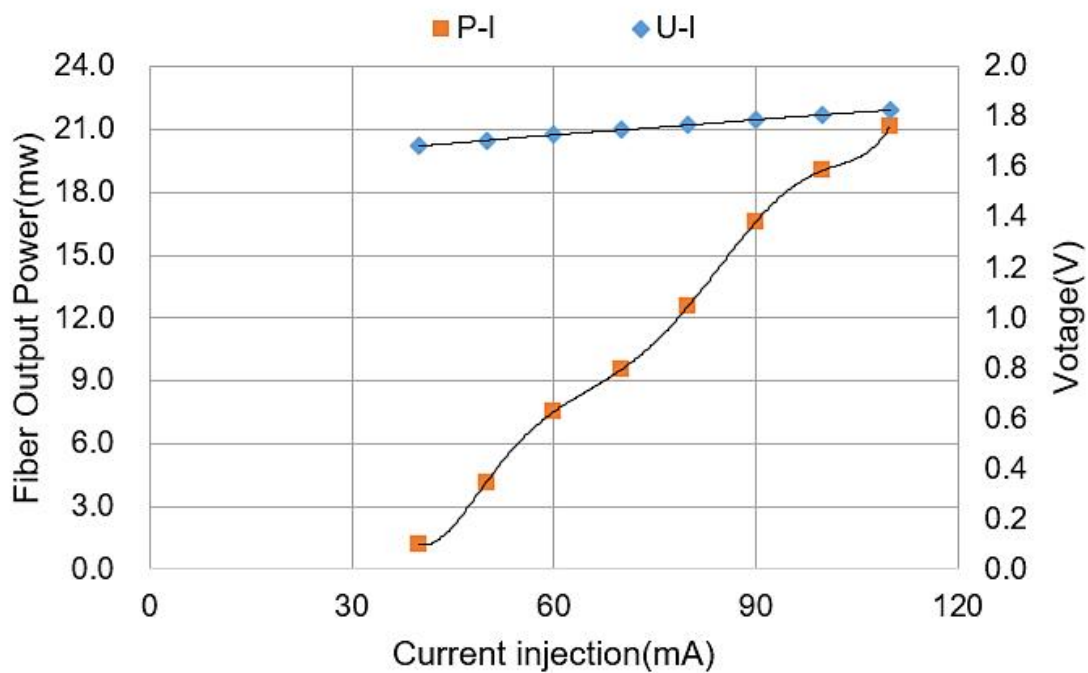

Linewidth Testing Result

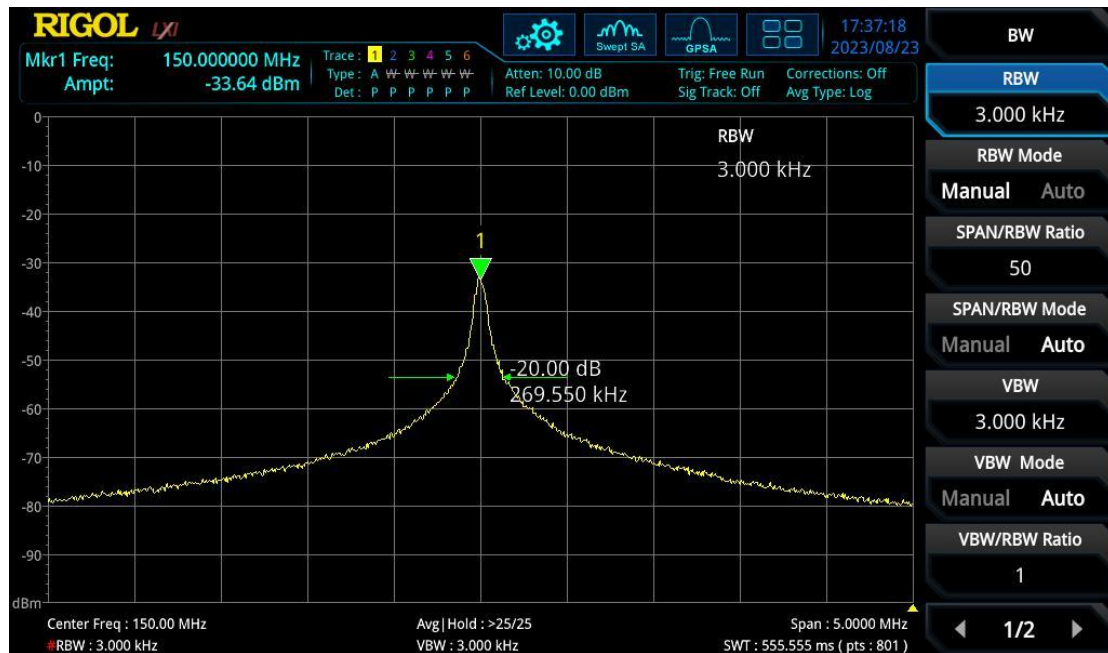

Working Structure

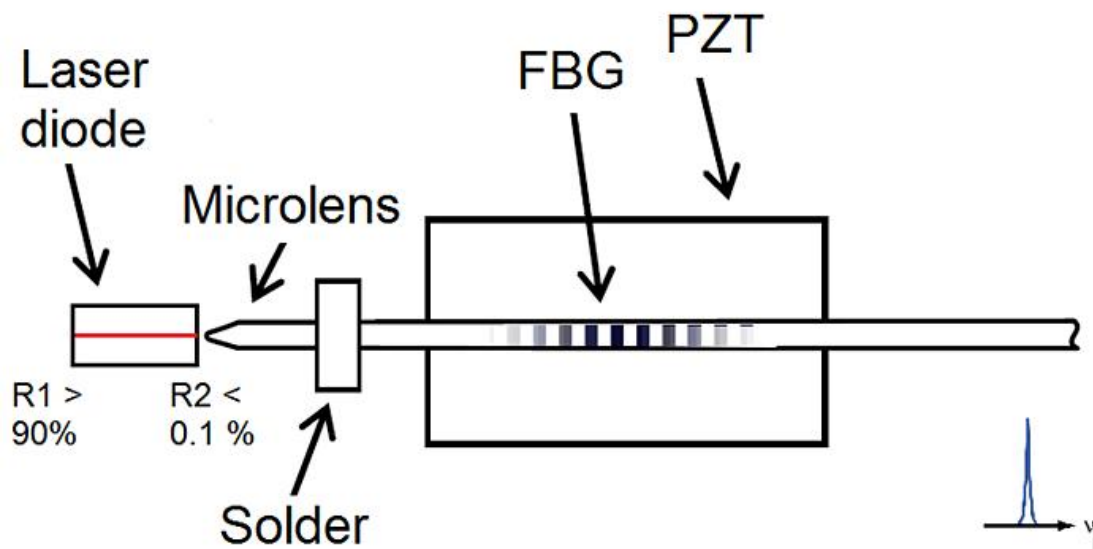



Beam Quality(M2,2D/3D Beam)

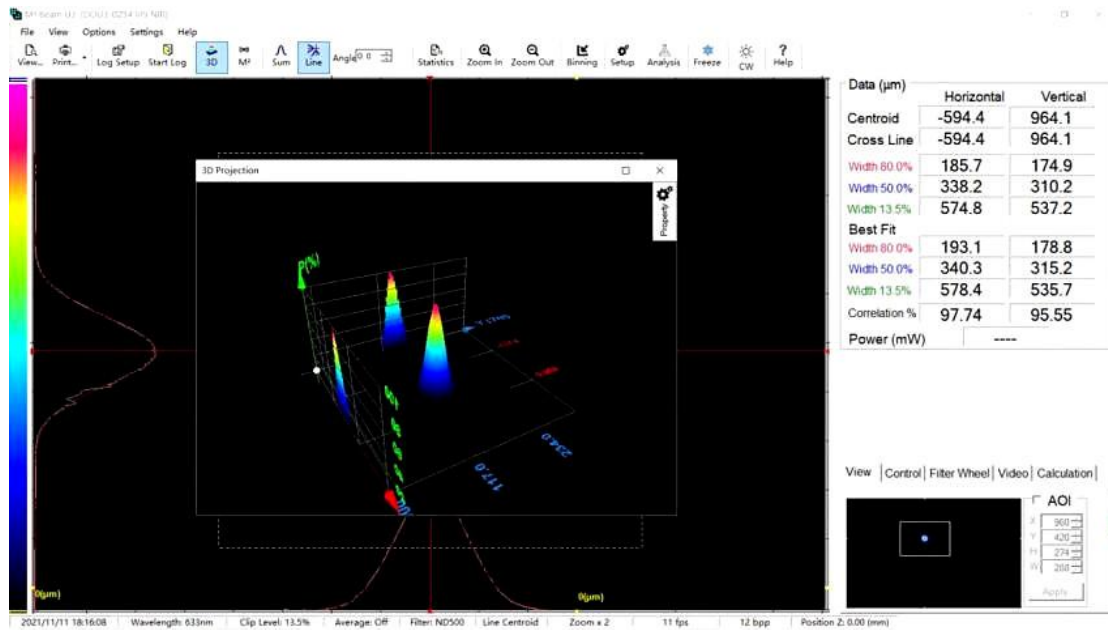
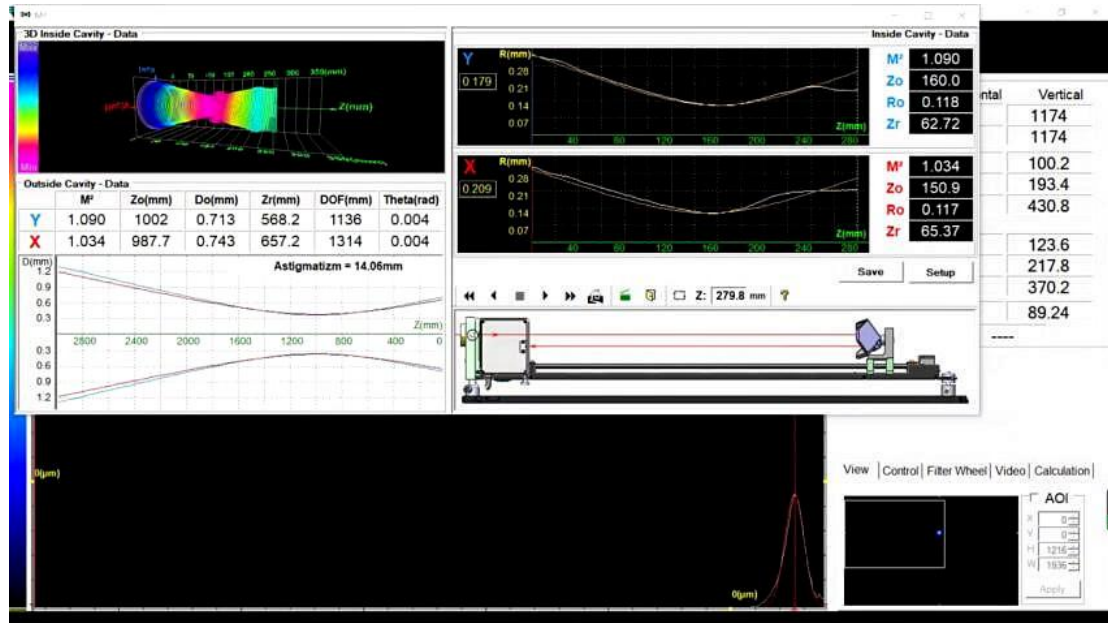

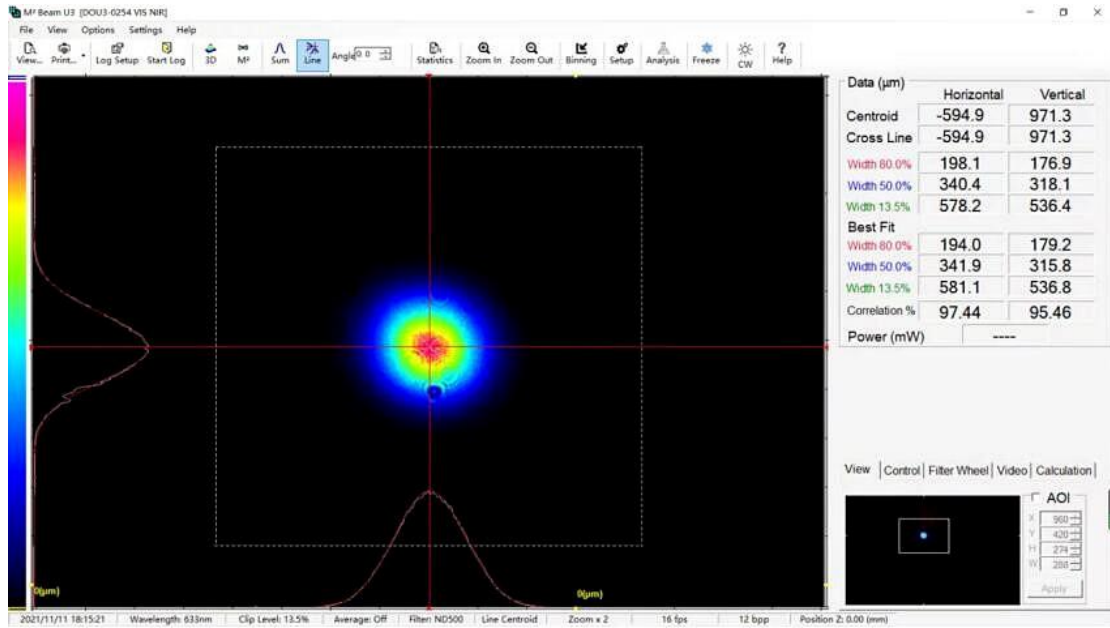

Absolute maximum ratings:

Parameter	Unit	Min	Typ	Max
Case Temperature	°C	-40	25	70
Chip Temperature	°C	+10	25	40
Operating Current	mA	0	150	170
Forward Voltage	V	0.8	1.2	1.8
TEC Current	A	-	1.2	1.4
Reverse Voltage(LD)	V	-	-	1.8



Pin definition

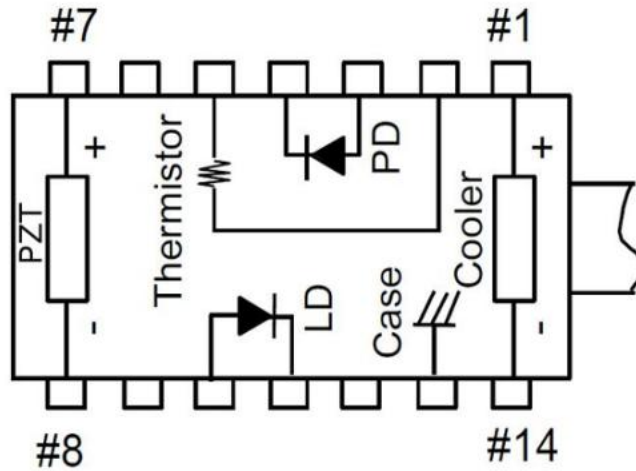

None PZT Built inside			
NO	Parameter	NO	Parameter
1	Cooler anode+	8	PZT tuning -
2	Thermistor	9	NC
3	PD anode-	10	LD anode+
4	PD cathode+	11	LD cathode-
5	Thermistor	12	NC
6	NC	13	Case
7	PZT tuning +	14	Cooler cathode-

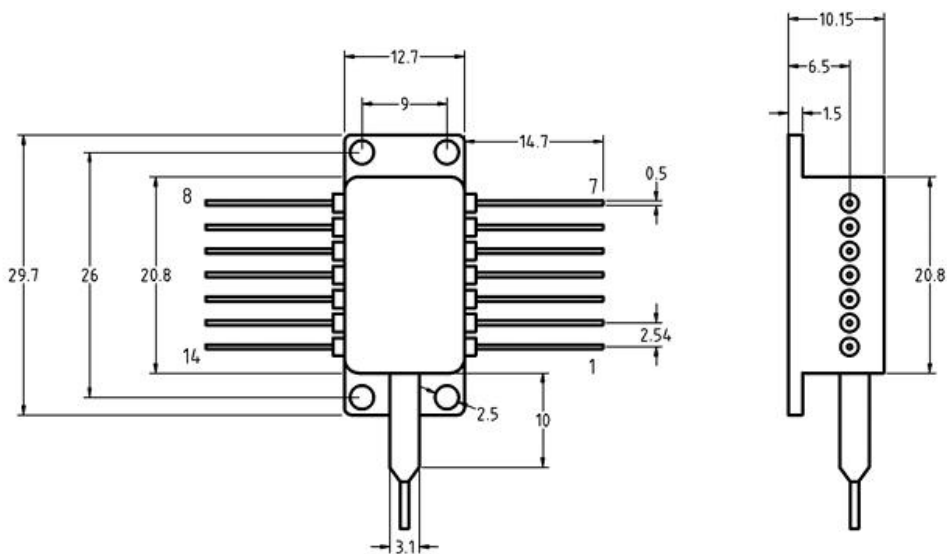

Fiber Pigtail Specifications

Parameters	Description
Fiber Type	SM fiber
Jacket Type	900μm loose tube
Pigtail Length	1.0±0.1m
Connector Type	FC/APC
PM fiber Connector Orientation	Please see the right figure

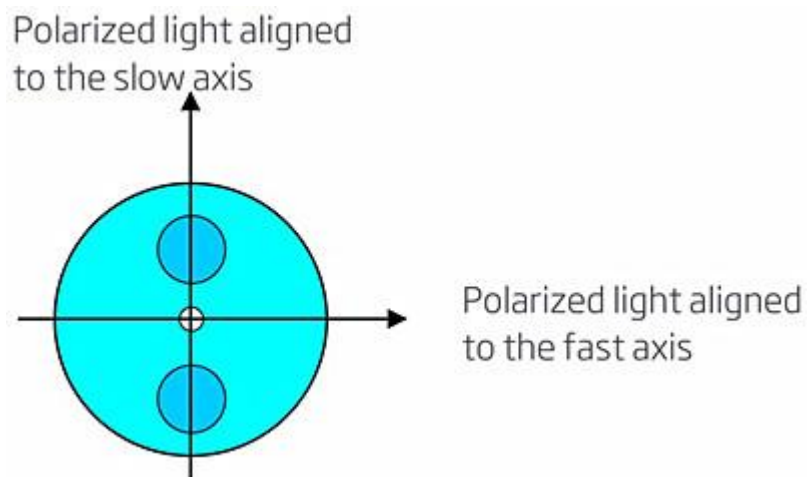

Note: The PM fiber and the connector key are aligned to the slow axis, fast axis is blocked